



جامعة الإمام محمد بن سعود الإسلامية  
IMAM MOHAMMAD IBN SAUD ISLAMIC UNIVERSITY

**Department of Chemical Engineering**

# **Heat Transfer Lab**

## **ChE-322 Manual**

**Instructor:**

**Eng. Najem Alarwan**

**STUDENT NAME:**

**STUDENT NUMBER:**

**SEMESTER / YEAR:**

## Table of Contents

Safety Rules and Regulations .....	3
Grading Criteria.....	4
Instructions for students .....	4
EXPERIMENT #01: STEADY STATE HEAT TRANSFER BY CONDUCTION.....	5
EXPERIMENT #02: DETERMINATION OF OVERALL HEAT TRANSFER COEFFICIENT AND THERMAL CONDUCTIVITY OF MATERIALS.....	12
EXPERIMENT #03 & #04:FREE AND FORCED CONVECTION ON FIN /TUBE BUNDLE HEATER.....	18
EXPERIMENT #05:COMBINED NATURAL CONVECTION AND RADIATION HEAT TRANSFER.....	23
EXPERIMENT #06:COMBINED FORCED CONVECTION AND RADIATION HEAT TRANSFER.....	29
EXPERIMENT #07:STEADY STATE HEAT TRANSFER IN HEAT EXCHANGER (1) .....	35
EXPERIMENT #08:STEADY STATE HEAT TRANSFER IN HEAT EXCHANGER (2) .....	41
EXPERIMENT #09:STEADY STATE HEAT TRANSFER IN HEAT EXCHANGER (3) .....	44
EXPERIMENT #10:FILM AND DROP WISE CONDENSATION .....	47
EXPERIMENT #11:NUCLEATE BOILING .....	51

## Safety Rules and Regulations

- Safety is for your health. Good lab techniques coupled with safety is not a mark of professional pride but also enables you to avoid accidents.
- Laboratory **safety is the top priority** and applicable to all personnel working including lab staff and, ensure to be observing safe practices at all times.
- Make sure you understand how the experimental **apparatus works** and do all of the adjustments before you attempt to operate it
- The **written approval** of the instructor is required for anyone to be in the laboratory after hours, or on non-scheduled laboratory days.
- Only the equipment pertaining to the assigned experiment is to be operated.
- **Horseplay** of any sort is absolutely prohibited in the laboratory.
- **Smoking** and open **flames** are prohibited in the laboratory.
- No operating equipment will be left unattended. At least two members of the group must be present while the equipment is operating.
- Food and drink are forbidden in laboratories.
- Avoid unnecessary fluid **leakage**, waste of water, or waste of energy
- Avoid **inhalation** of gases and vapors of any kind
- Care must be used in the **handling** of chemicals to avoid spills and to avoid contact with the skin.
- Practice **housekeeping**; remove any trash, waste, spillage of water.
- Before leaving the lab, ensure the chemical are returned to proper cabinet, glassware being washed and equipment properly shut-down.

## **Grading Criteria**

Quizzes .....	20 % marks
Report + Presentation.....	40% marks
Oral Examination .....	40%marks

## **Instructions for students**

Students are required to complete practical from the list provided.

Ensure that you read through each experiment prior to commencement and discuss with the laboratory supervisor.

Laboratory reports must be written following the completion of each experiment and handed to the laboratory supervisor next week after the experiment performed.

## EXPERIMENT #01 (HT-01)

### STEADY STATE HEAT TRANSFER BY CONDUCTION

#### OBJECTIVE:

1. To measure the temperature distribution for steady state heat transfer by conduction through a uniform plane wall and demonstrate the effect of a change in heat flow.
2. To understand the use of the Fourier rate equation in determining rate of heat flow for one-dimensional steady flow of heat.
3. To demonstrate the effect of contact resistance on thermal conduction between adjacent materials.
4. To demonstrate that temperature gradient is inversely proportional to the cross-sectional area for one-dimensional flow of heat in a solid material of constant thermal conductivity.

#### THEORITICAL BACKGROUND

Conduction is the transfer of heat energy by microscopic diffusion and collisions of particles or quasi-particles within a body due to a temperature gradient. The process of heat transfer by conduction can be described by the Fourier's law. If a plane wall of thickness  $\Delta X$  and area of  $A$  supports a temperature difference  $\Delta T$  then the heat transfer rate per unit time ( $Q$ ) by conduction through the wall is found to be

$$Q_{\text{tot}} \propto A \frac{\Delta T}{\Delta X} = -kA \frac{\Delta T}{\Delta X} \quad \dots(1)$$

The cross-sectional area of cylinder is formulated as follows

$$A = \frac{\pi D^2}{4} \quad \dots(2)$$

While heat transfer per unit time can also be expressed as

$$Q_{\text{tot}} = VI \quad \dots(3)$$

When two surfaces are not metallurgically bonded together, they will create a resistance to heat flow. The reason for this resistance is related to the fact that due to surface roughness, contact takes place at a limited number of spots. The voids are filled with air or the surrounding fluid, which obviously has conductivity smaller by orders of magnitude.

## DESCRIPTION OF THE EQUIPMENT

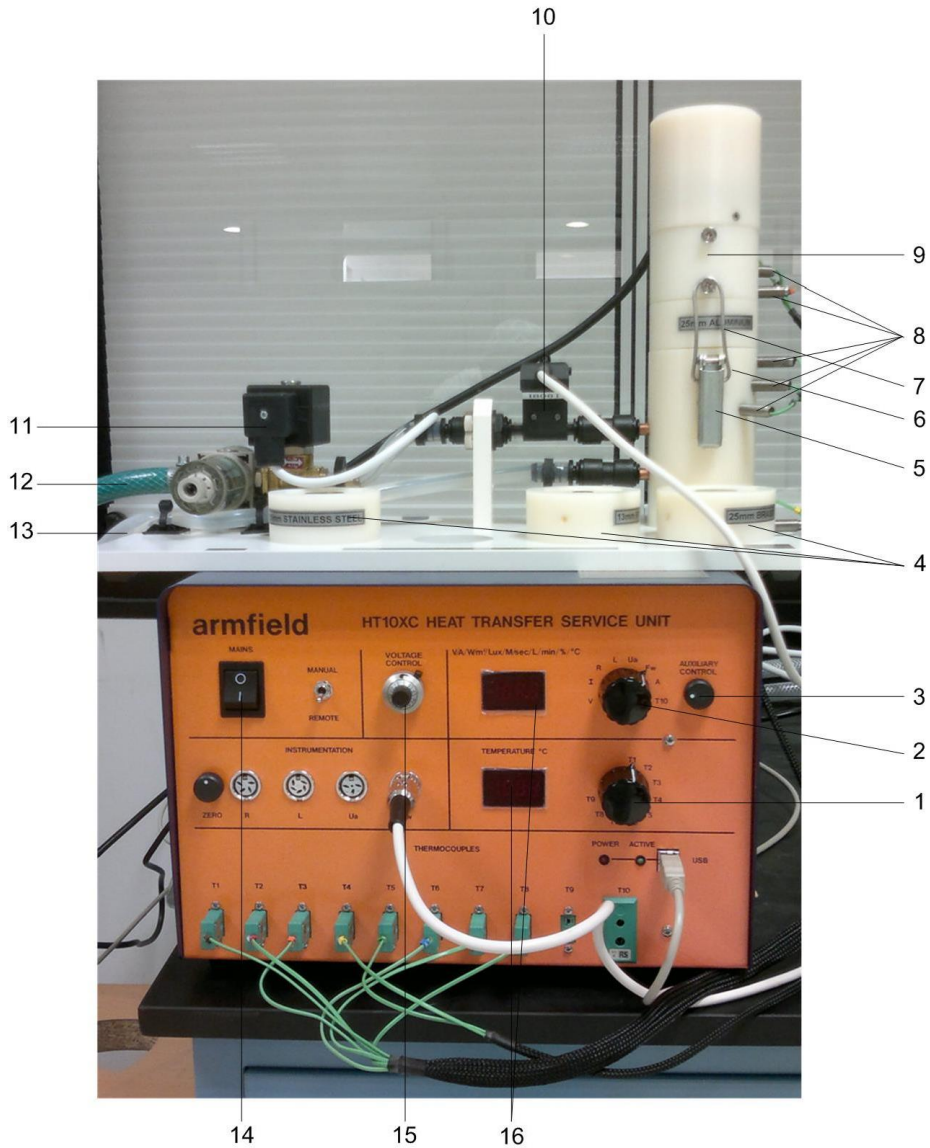

Figure 1. Linear Conduction Heat Transfer Unit

The linear conduction unit has two main units HT10XC which is basically heat transfer service unit and HT11C which is compatible Linear Head Conduction Accessory. The heat transfer service unit HT10XC has main switch (14) to turn on or off the system. The heat load is controlled using voltage potentiometer (15). The cooling water flow rate can be adjusted using auxiliary control knob (3). All measurements including voltage, current, cooling water flowrate, etc can be read manually through two digital panels (16) using two selector knobs (1 and 2) accordingly.

Meanwhile, HT11C has metal specimens covered with insulator. The hot portion (9) is at the top next to the heater, while the cold portion (8) is placed at the bottom next to cooling water circulation. Both portions are clamped (5) to have a better contact. Cooling water is

introduced and pumped (11) through inlet tube (12) and leaves the system through outlet tube (13). The intermediate portion (7) can be changed with different type of metals such as stainless steel and aluminium (4) for example. The thermocouples (8) are installed at certain distance starting from the top portion to the bottom one.

## **EXPERIMENTAL PROCEDURE**

### **Experiment 1: Temperature Distribution for Steady State Heat Transfer by Conduction.**

1. Clamp the heated and cooled section of the HT11C together with having brass in the middle section.
2. Switch on the front mains switch and check that the panel displays on the service unit must be illuminated.
3. Turn on the cooling water and adjust the flow control valve to give approximately 1.5 L/min. (If using computer the flow rate can be controlled using the control box the software diagram window).
4. Set the heater voltage at 9 V (if using the computer, enter the voltage in the display box for the heater).
5. Allow the HT14C to stabilize and monitor the temperature of the cylinder using the software display or using the lower selector switch.
6. Take all measurement for T1, T2, T3, T4, T5, T6, T7, T8, V, I and Tw.
7. Do the same procedure for 12 V, 17 V and 21 V. (for 12 V and 17 V, do also experiment 2)

### **Experiment 2: Effect of Contact Resistance on Thermal Conduction**

1. After doing the above experiment for the voltage of 12 V, unclamp the heated, intermediate and cooled section.
2. Allow the HT14C to stabilize and monitor the temperature of the cylinder using the software display or using the lower selector switch
3. Take all measurement for T1, T2, T3, T4, T5, T6, T7, T8, V, I and Tw
4. Repeat this experiment for voltage of 17 V.

### **Experiment 3: Effect of Cross-Sectional Area on Thermal Conduction**

1. Turn off the main switch and cooling water
2. Replace the intermediate brass section with other intermediate brass section but with smaller diameter.
3. Turn on the cooling water and adjust the flow control valve to give approximately 1.5 L/min. (If using computer the flow rate can be controlled using the control box the software diagram window).
4. Set the heater voltage at 12 V (if using the computer, enter the voltage in the display box for the heater).
5. Allow the HT14C to stabilize and monitor the temperature of the cylinder using the software display or using the lower selector switch.
6. Take all measurement for T1, T2, T3, T6, T7, T8, V, I and Tw.
7. Do the same procedure for 17 V.

## **REFERENCES**

Computer Compatible Linear Heat Conduction, 2011, Experiment Instructions, ARMFIELD

## NOTATION

A	:	Cross Sectional Area, m <sup>2</sup>
D	:	Outside diameter, m
V	:	Voltage to heating element, V
I	:	Current to heating element, A
$\Delta X$	:	Wall thickness, m
Q	:	Electrical power to heating element, W
T <sub>hotface</sub>	:	Temperature at hot interface, °C
T <sub>coldface</sub>	:	Temperature at cold interface, °C
T <sub>1</sub>	:	Measured Temperature, °C
$\Delta T$	:	Temperature difference, °C
Fw	:	Flow of cooling water, l/min
U	:	Overall heat transfer coefficient, W/m <sup>2</sup> .°C
R	:	Resistance to heat flow, m <sup>2</sup> .°C/W
k	:	Thermal conductivity, W/m.°C
Grad	:	Temperature gradient, W/m.°C
t	:	Time, secs
FW	:	Volumetric Flowrate of cooling water, L/min



## WORK SHEETS

**Experiment 1:**  
**FW = 1.5 L/min**

V (volt)	I (A)	T1 (°C)	T2 (°C)	T3 (°C)	T4 (°C)	T5 (°C)	T6 (°C)	T7 (°C)	T8 (°C)
9									
12									
17									
21									

The following constants are applicable for experiment 1 and 2:

Distance between each thermocouple, m	0.015
Distance between T3, T4, T5, or T6 to the end face, m	0.015
Diameter of bar, m	0.25

After filling out the above table, do the following analysis

Cross sectional area, m <sup>2</sup>	
Distance of T1 – T3 (X13) , m	
Distance of T4 – T5 (X45) , m	
Distance of T6 – T8 (X68) , m	

Voltage, V		9	12	17	21
Heat flow (power to heater), W	$Q = VI$				
Temperature difference in heated section, °C	$\Delta T_{hot} = T1 - T3$				
Conductivity in heated section, W/m °C	$k_{hot} = \frac{X_{13}Q}{\Delta T_{hot}A}$				
Temperature difference in intermediate section, °C	$\Delta T_{int} = T4 - T5$				
Conductivity in intermediate section, W/m °C	$k_{int} = \frac{X_{45}Q}{\Delta T_{int}A}$				
Temperature difference in cooled section, °C	$\Delta T_{coSd} = T6 - T8$				
Conductivity in cooled section, W/m °C	$k_{coSd} = \frac{X_{68}Q}{\Delta T_{coSd}A}$				

- Compare the changes in temperature in the two sections (heated and cooled section) at the same heat flow and at different heat flows.
- Plot a graph of temperature against position along the bar and observe the temperature profile.
- Compare the calculated conductivity in the three sections (heated, intermediate and cooled section) at the same heat flow and at different heat flows.

**Experiment 2**  
**FW = 1.5 L/min**

V (volt)	I (A)	T1 (°C)	T2 (°C)	T3 (°C)	T4 (°C)	T5 (°C)	T6 (°C)	T7 (°C)	T8 (°C)
12									
17									

- Plot a graph of temperature against position along the bar and observe the temperature profile.
- Compare the plot of temperature against position along the bar for experiment 1 and experiment 2

**Experiment 3:**  
**FW = 1.5 L/min**

V (volt)	I (A)	T1 (°C)	T2 (°C)	T3 (°C)	T6 (°C)	T7 (°C)	T8 (°C)
12							
17							

The following constants are applicable for experiment 3:

Distance between each thermocouple	0.015
Distance between T3 or T6 to the end face	0.0075
Distance between hot face to cold face	0.030
Diameter of bar ( $D_{hot}$ ), m	0.25
Diameter of bar ( $D_{red}$ ), m	0.13
Diameter of bar ( $D_{cold}$ ), m	0.25
Brass conductivity (use result from experiment 1)	

After filling out the above table, do the following **analysis**

Cross sectional area, $m^2$	
Cross sectional of reduced area, $m^2$	
Distance of T1 – T3 (X13) , m	
Distance of hotface – coldface (Xred) , m	
Distance of T6 – T8 (X68) , m	

Voltage, V		12	17
Heat flow (power to heater), W	$Q = VI$		
Temperature difference in heated section, °C	$\Delta T_{hot} = T1 - T3$		
Temperature gradient in heated section, °C/m	$Grad_{hot} = \frac{\Delta T_{hot}}{X13}$		
Temperature at hot-face of reduced section, °C	$T_{hotface} = T3 - \frac{T2 - T3}{2}$		
Temperature at cold-face of reduced section, °C	$T_{coldface} = T6 + \frac{T6 - T7}{2}$		

Temperature difference in reduced section, °C	$\Delta T_{red} = T_{hotface} - T_{coSdface}$		
Temperature gradient in reduced section, °C/m	$Grad_{red} = \frac{\Delta T_{red}}{X_{red}}$		
Temperature difference in cooled section, °C	$\Delta T_{coSd} = T_6 - T_8$		
Temperature gradient in cooled section, °C/m	$Grad_{coSd} = \frac{\Delta T_{coSd}}{X_{68}}$		
Ratio of temperature gradients	$\frac{Grad_{red}}{Grad_{hot}}$		
Ratio of cross sections	$\frac{A_{red}}{A_{hot}}$		

Plot a graph of temperature against position along the bar.

Answer the following questions:

1. What is conduction heat transfer?
2. How does conduction differ from other type of heattransfer?
3. Explain why there is resistance to heat flow between two surfaces which are not metallurgically bonded?

## EXPERIMENT #02 (HT-02)

### DETERMINATION OF OVERALL HEAT TRANSFER COEFFICIENT AND THERMAL CONDUCTIVITY OF MATERIALS

#### OBJECTIVE:

1. To measure the temperature distribution for steady-state conduction of energy through a composite plane wall and determine its overall heat transfer coefficient.
2. To determine the thermal conductivity  $k$  (the constant of proportionality) of a metal specimen.
3. To understand the application of poor conductors (insulators), and determine the thermal conductivity  $k$  of an insulator.

#### THEORITICAL BACKGROUND

The heated, intermediate, and cooled sections are clamped tightly together, so that the end-faces are in good thermal contact.

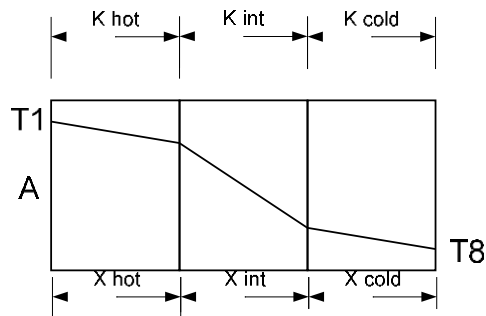

Figure 1. Schematic Temperature Distribution in a Composite Plane Wall

For continuity, the steady heat flow through the successive sections must be the same so Fourier's law can be applied to the three sections as follows:

$$\frac{Q_{tot}}{A} = \frac{k_{hot} \Delta T_{hot}}{\Delta X_{hot}} = \frac{k_{int} \Delta T_{int}}{\Delta X_{int}} = \frac{k_{cold} \Delta T_{cold}}{\Delta X_{cold}} \quad \dots(1)$$

From which it follows:

$$\frac{Q_{tot}}{A} = U(T1 - T8) \quad \dots(2)$$

While overall heat transfer coefficient  $U$  is defined as follows

$$\frac{1}{U} = R = \frac{\Delta X_{hot}}{k_{hot}} + \frac{\Delta X_{int}}{k_{int}} + \frac{\Delta X_{cold}}{k_{cold}} \quad \dots(3)$$

$R$  is the resistance to heat flow.

Using equation (1), we can also determine the conductivity ( $k$ ) for specific metals for example for intermediate part.

$$k = \frac{Q_{\text{tot}} \Delta X_{\text{int}}}{A_{\text{int}} \Delta T_{\text{int}}} = \frac{Q_{\text{tot}} \Delta X_{\text{int}}}{A_{\text{int}} (T_{\text{Mot-face}} - T_{\text{cold-face}})} \quad \dots(4)$$

By replacing the intermediate part with insulator such as paper or cork, we can use equation 4 to calculate the conductivity of such insulators.

$$k = \frac{Q_{tot}\Delta X_{ins}}{A_{ins}\Delta T_{ins}} = \frac{Q_{tot}\Delta X_{ins}}{A_{ins}(T_{hot-face}-T_{cold-face})} \quad \dots(5)$$

Where

$$T_{hot-face} = T3 - \frac{T2-T3}{2} \quad \dots(6)$$

$$T_{cold-face} = T6 - \frac{T6-T7}{2} \quad \dots(7)$$

### DESCRIPTION OF THE EQUIPMENT

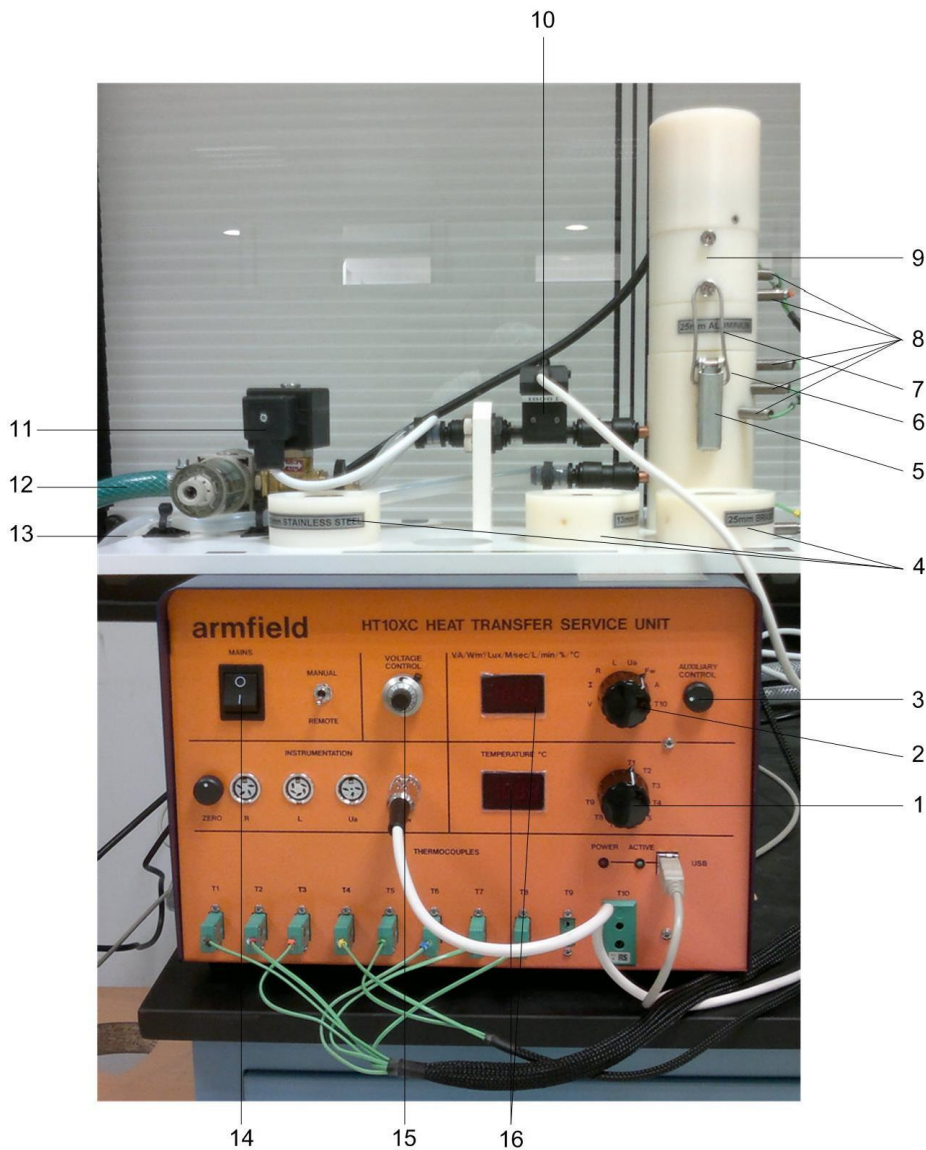

Figure 2. Linear Conduction Heat Transfer Unit

The linear conduction unit has two main units HT10XC which is basically heat transfer service unit and HT11C which is compatible Linear Head Conduction Accessory. The heat transfer service unit HT10XC has main switch (14) to turn on or off the system. The heat load is controlled using voltage potentiometer (15). The cooling water flow rate can be adjusted using auxiliary control knob (3). All measurements including voltage, current, cooling water flowrate, etc can be read manually through two digital panels (16) using two selector knobs (1 and 2) accordingly.

Meanwhile, HT11C has metal specimens covered with insulator. The hot portion (9) is at the top next to the heater, while the cold portion (8) is placed at the bottom next to cooling water circulation. Both portions are clamped (5) to have a better contact. Cooling water is introduced and pumped (11) through inlet tube (12) and leaves the system through outlet tube (13). The intermediate portion (7) can be changed with different type of metals such as stainless steel and aluminium (4) for example. The thermocouples (8) are installed at certain distance starting from the top portion to the bottom one.

## **EXPERIMENTAL PROCEDURE**

### **Experiment 1: Determination of Overall Heat Transfer Coefficient**

8. Clamp the heated and cooled section of the HT11C together with having aluminium in the middle section.
9. Switch on the front mains switch and check that the panel displays on the service unit must be illuminated.
10. Turn on the cooling water and adjust the flow control valve to give approximately 1.5 L/min. (If using computer the flow rate can be controlled using the control box the software diagram window).
11. Set the heater voltage at 12 V (if using the computer, enter the voltage in the display box for the heater).
12. Allow the HT14C to stabilize and monitor the temperature of the cylinder using the software display or using the lower selector switch.
13. Take all measurement for T1, T2, T3, , T6, T7, T8, V, I and Tw.
14. Do the same procedure for 17 V.

### **Experiment 2: Effect of Contact Resistance on Thermal Conduction**

1. Clamp the heated and cooled section of the HT11C together with having paper in the middle section.
2. Switch on the front mains switch and check that the panel displays on the service unit must be illuminated.
3. Turn on the cooling water and adjust the flow control valve to give approximately 1.5 L/min. (If using computer the flow rate can be controlled using the control box the software diagram window).
4. Set the heater voltage at 1.5 V (if using the computer, enter the voltage in the display box for the heater).
5. Allow the HT14C to stabilize and monitor the temperature of the cylinder using the software display or using the lower selector switch. **12**
6. Take all measurement for T1, T2, T3, , T6, T7, T8, V, I and Tw.
7. Do the same procedure for 2 V.

## REFERENCES

Computer Compatible Linear Heat Conduction, 2011, Experiment Instructions, ARMFIELD

## NOTATION

A	:	Cross Sectional Area, m <sup>2</sup>
D	:	Outside diameter, m
V	:	Voltage to heating element, V
I	:	Current to heating element, A
$\Delta X$	:	Wall thickness, m
Q	:	Electrical power to heating element, W
T <sub>hot-face</sub>	:	Temperature at hot interface, °C
T <sub>cold-face</sub>	:	Temperature at cold interface, °C
T <sub>1</sub>	:	Measured Temperature, °C
$\Delta T$	:	Temperature difference, °C
F <sub>w</sub>	:	Flow of cooling water, l/min
U	:	Overall heat transfer coefficient, W/m <sup>2</sup> .°C
R	:	Resistance to heat flow, m <sup>2</sup> .°C/W
k	:	Thermal conductivity, W/m.°C
Grad	:	Temperature gradient, W/m.°C
t	:	Time, secs
FW	:	Volumetric flowrate of cooling water, L/min



## WORK SHEETS

### Experiment 1 FW = 1.5 L/min

V (volt)	I (A)	T1 (°C)	T2 (°C)	T3 (°C)	T6 (°C)	T7 (°C)	T8 (°C)
12							
17							

The following constants are applicable for experiment

Distance between each thermocouple	0.015
Distance between T3 or T6 to the end face	0.0075
Distance between hot face to cold face	0.030
Diameter of bar ( $D_{hot}$ ), m	0.25
K hot (use result from conduction -1)	
K cold (use result from conduction -1)	

After filling out the above table, do the following analysis:

Cross sectional area, $m^2$	
Cross sectional of reduced area, $m^2$	
Distance of T1 - T3 (X13), m	
Distance of hotface - coldface (Xred), m	
Distance of T6 - T8 (X68), m	

Voltage, V		12	17
Heat flow (power to heater), W	$Q = VI$		
Temperature difference in intermediate section, °C	$\Delta T_{int} = T4 - T5$		
Conductivity in intermediate section, W/m °C	$k_{int} = \frac{X_{45}Q}{\Delta T_{int}A}$		
Temperature difference across composite wall, °C	$\Delta T_{18} = T1 - T8$		
Resistance to heat flow, m °C /W	$R = \frac{\Delta X_{hot}}{k_{hot}} + \frac{\Delta X_{int}}{k_{int}} + \frac{\Delta X_{coSd}}{k_{coSd}}$		
Overall heat transfer coefficient, W/m °C	$U = \frac{Q_{tot}}{A(T1 - T8)}$		

- c. Plot a graph of temperature against position along the bar and observe the temperature profile.
- d. Compare the two values obtained for the overall heat transfer coefficient U and  $U=1/R$  and comment on any difference in the values obtained. **14**

**Experiment 2:**  
**FW = 1.5 L/min**

V (volt)	I (A)	T1 (°C)	T2 (°C)	T3 (°C)	T6 (°C)	T7 (°C)	T8 (°C)
1.5							
2							

The following constants are applicable for experiment 3:

Distance between each thermocouple	0.015
Distance between T3 or T6 to the end face	0.0075
Diameter of insulator (D), m	0.25
Brass conductivity (use result from experiment 1)	

After filling out the above table, do the following **analysis**

Cross sectional area, m <sup>2</sup>	
Cross sectional of reduced area, m <sup>2</sup>	
Distance of T1 – T3 (X13) , m	
Distance of hotface – coldface (Xred) , m	
Distance of T6 – T8 (X68) , m	

Voltage, V		1.5	2
Heat flow (power to heater), W	$Q = VI$		
Temperature at hot-face of insulator, °C	$T_{\text{hotface}} = T3 - \frac{T2 - T3}{2}$		
Temperature at cold-face of insulator, °C	$T_{\text{coldface}} = T6 + \frac{T6 - T7}{2}$		
Temperature difference at insulator, °C	$\Delta T_{\text{inc}} = T_{\text{hotface}} - T_{\text{coldface}}$		
Conductivity in intermediate section, W/m °C	$k_{\text{int}} = \frac{X_{45}Q}{\Delta T_{\text{int}}A}$		

- Plot a graph of temperature against position along the bar.
- Comment on the above calculated results.

Answer the following questions:

- What is the effect of insulator?
- What is the difference between insulator and conductor?

## EXPERIMENT #03 and #04 (HT-03 and HT-04)

### FREE AND FORCED CONVECTION ON FIN /TUBE BUNDLE HEATER

#### OBJECTIVE

1. To study the effect of surface temperature and air velocity on the heat transfer in fin/tube bundle.
2. To investigate the effect of the shape of the heater on heat transfer.
3. To calculate heater efficiency.

#### THEORITICAL BACKGROUND

The field of heat transfer in industry and technology is a wide one. Machines that produce heat by converting energy are used in many fields. Whether this heat is dissipated as waste heat or re-used is not important in heat transfer. What is important here are the mechanisms that allow this form of energy to be transported. The temperature is directly related to the amount of stored heat of a matter. Heat can be transferred through a variety of different mechanisms such as radiation, conduction and convection.

In this experiment, fin is used to enhance heat transfer from the heater block to the surrounding air. Fin is one of extended surface that is also commonly used in the industry. In many cases, fin will be effective if the surrounding medium has low conductive heat transfer coefficient i.e. gases (not liquid). In addition, fin must also be closely spaced, thin and short.

Convection is a heat transfer because the fluid particles movement. Therefore heat transfer by convection is mainly determined by the fluid velocity. There are two types of convection i.e. free convection and forced convection. In free convection, the heater element releases its heat to the air. The heated air flows upwards through the resulting difference in density. In forced convection, the flow is made possible by an outside technical device, such as a fan. The quicker transport of the fluid causes a higher temperature gradient from the warm surface to the fluid and thus a better heat transfer.

The heat transfer can be calculated as follows

$$\dot{Q} = N C_p (T_2 - T_1) \quad \dots(1)$$

While the air mass flow rate  $m$  is

$$N = v A_d \rho \quad \dots(2)$$

Density of air can be found in Appendix.

Another approach to calculate the heat transfer is

$$\dot{Q} = h A_h (T_4 - T_1) \quad \dots(3)$$

And heat transfer coefficient can be calculated as follows

$$h = \frac{N c_p (T_2 - T_1)}{A_h (T_4 - T_1)} = f(Nu) \quad \dots(4)$$

#### DESCRIPTION OF THE EQUIPMENT

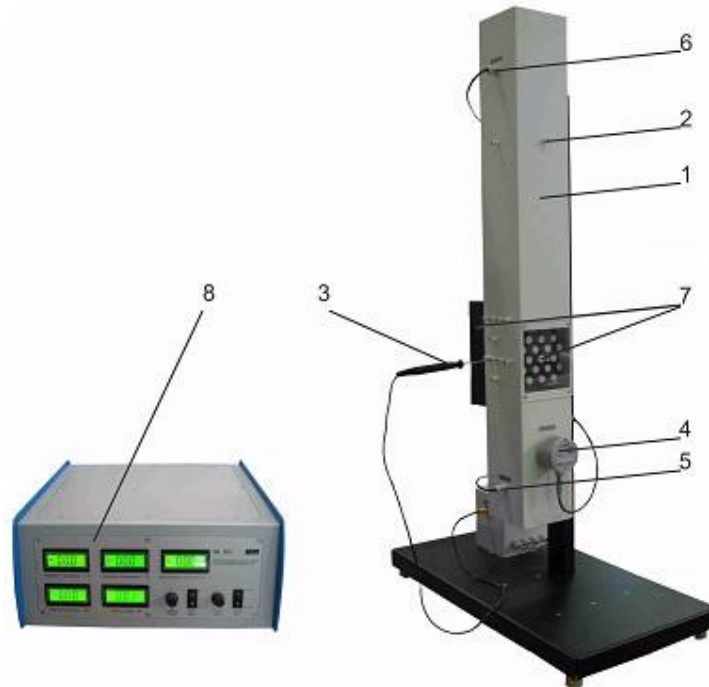

Figure 1. Free and Force Convection Unit

The unit consists of mainly the air duct (1) with a flow cross-section of 120 mm x 120 mm and with a length of 1m. It has measuring glands (2) which allow it to detect the temperature at different points by inserting a thermocouple (3). In addition, flow sensor (4) is also available to record the entry velocity of the air. Temperature sensor (Pt100 element) (5,6) will record the inlet and outlet air temperatures. Different type of heater (7) can be inserted into the duct and each heater is operated via four heating resistors with a maximum total output of approximately 170 W. Both power supply and air flow rate can be easily control using the control and display unit (8). It also displays all parameters being measured in the experiments.

## EXPERIMENTAL PROCEDURE

### Effect of Heater Temperature on Heat Transfer

1. Install fin/tube bundle heater block as shown in figure 1.
2. Turn on the heater and set the heater power to 100 W.
3. Record all temperatures when it reaches steady state (approximately 30 min).
4. Repeat step 3 for heater power of 125 W and 150 W.

### Effect of Air Flow Velocity on Heat Transfer

1. Keep the heater power at 150 W, turn on the fan, and set the air flow rate at 0.5 m/s.
2. Record all temperatures when it reaches steady state (approximately 30 min).
3. Repeat step 2 for air flow rate of 1.5 m/s and 2.5 m/s.

## REFERENCES

**NOTATION**

- $A_d$  : Cross Sectional Area of The Air Duct,  $m^2$
- $A_h$  : Surface Area of the heater,  $m^2$
- $C_p$  : Specific Heat Capacity,  $J/kg.K$
- $\Delta T$  : Temperature Gradient,  $K$
- $h$  : Heat Transfer Coefficient of The Heater,  $W/m^2.K$
- $m$  : Mass flow rate of air,  $kg/s$
- $Q$  : Heat load,  $W$
- $T_1$  : Air Inlet Temperature,  $^{\circ}C$
- $T_2$  : Air Outlet Temperature,  $^{\circ}C$
- $T_4$  : Average Surface Temperature,  $^{\circ}C$
- $Nu$  : Nusselt Number
- $v$  : Air velocity,  $m/s$
- $\rho$  : Air Density,  $kg/m^3$

**Appendix  
Technical Data**

- Air Duct Cross Section :  $0.0144 m^2$
- Pipe Bundle Area :  $0.098 m^2$
- Fins Area :  $0.14 m^2$

Physical Properties of Air at P= 1 Bar

$T$ in $^{\circ}C$	$\rho$ in $\frac{kg}{m^3}$	$c_p$ in $\frac{kJ}{kg.K}$	$\lambda$ in $\frac{W}{K.m}$	$\eta$ in $\frac{kg}{m.s}$	$\nu$ in $\frac{m^2}{s}$	$\alpha$ in $\frac{m^2}{s}$	$Pr$
-20	1,3765	1,004	0,02301	16,15	11,73	16,6	0,71
0	1,2754	1,004	0,02454	17,10	13,41	19,1	0,70
20	1,1881	1,007	0,02603	17,98	15,13	21,8	0,70
40	1,1120	1,008	0,02749	18,81	16,92	24,5	0,69
60	1,0452	1,009	0,02894	19,73	18,88	27,4	0,69
80	0,9859	1,010	0,03038	20,73	21,02	30,5	0,69
100	0,9329	1,012	0,03181	21,60	23,15	33,7	0,69
120	0,8854	1,014	0,03323	22,43	25,33	37,0	0,68
140	0,8425	1,017	0,03466	23,19	27,53	40,5	0,68
160	0,8036	1,020	0,03607	24,01	29,88	44,0	0,68
180	0,7681	1,023	0,03749	24,91	32,43	47,7	0,68
200	0,7356	1,026	0,03891	25,70	34,94	51,6	0,68
250	0,6653	1,035	0,04243	27,40	41,18	61,6	0,67
300	0,6072	1,046	0,04591	29,20	48,09	72,3	0,67
400	0,5170	1,069	0,05257	32,55	62,95	95,1	0,66
500	0,4502	1,093	0,05848	35,50	78,86	119	0,66
600	0,3986	1,116	0,0635	38,30	96,08	143	0,67
700	0,3577	1,137	0,0678	40,87	114,3	166	0,69
800	0,3243	1,155	0,0713	43,32	133,6	190	0,70
900	0,2967	1,171	0,0743	45,65	153,9	214	0,72
1000	0,2743	1,185	0,0768	47,88	175,1	237	0,74

**WORK SHEETS**

Heater Type : Fin/Tube bundle  
 Type of Experiment : Evaluation of the effect of temperature  
 Parameter : Electrical Power

Measuring point-measured values	Run 1	Run 2	Run 3	Run 4
Electrical Power (P), W	100	125	150	
Air Flow Velocity (v), m/s				
Inlet Temperature (T <sub>1</sub> ), °C				
Outlet Temperature (T <sub>2</sub> ), °C				
Heating Element Temperature (T <sub>4</sub> ), °C				
T4-1				
T4-2				
T4-3				
T4-4				
T4-5				
T4-6				

After Filling out the above table, calculate the value as listed below:

Values for Calculation	Run 1	Run 2	Run 3
Temperature Difference (T <sub>2</sub> -T <sub>1</sub> )			
Temperature Difference (T <sub>4</sub> -T <sub>1</sub> )			
Air Density			
Specific Thermal Capacity			
Thermal Energy			
Heater Surface			
Heat Transfer Coef.			
Nusselt Number			
Heating surface load			
Efficiency			

Heater type : Fin/Tube Bundle  
 Type of Experiment : Evaluation of the effect of air velocity  
 Parameter : Air velocity

Measuring point-measured values	Run 1	Run 2	Run 3
Electrical Power (P), W	150	150	150
Air Flow Velocity (v), m/s	0.5	1.5	2.5
Inlet Temperature (T <sub>1</sub> ), °C			
Outlet Temperature (T <sub>2</sub> ), °C			
Heating Element Temperature (T <sub>4</sub> ), °C			
T4-1			
T4-2			
T4-3			
T4-4			
T4-5			
T4-6			

After Filling out the above table, calculate the value as listed below:

Values for Calculation	Run 1	Run 2	Run 3
Temperature Difference (T <sub>2</sub> -T <sub>1</sub> )			
Temperature Difference (T <sub>4</sub> -T <sub>1</sub> )			
Air Density			
Specific Thermal Capacity			
Thermal Energy			
Heater Surface			
Heat Transfer Coef.			
Nusselt Number			
Heating surface load			
Efficiency			

Answer the following question:

- a. What is convection?
- b. What are the parameters that can affect heat transfer by convection?

## EXPERIMENT #05 (HT-05)

### COMBINED NATURAL CONVECTION AND RADIATION HEAT TRANSFER

#### OBJECTIVE:

1. To determine the combined heat transfer ( $Q_{\text{radiation}} + Q_{\text{convection}}$ ) from a horizontal cylinder in natural convection over a wide range of power inputs and corresponding surface temperatures also to demonstrate the relationship between power input and surface temperature in free convection.
2. To compare the contribution of heat transfer by convection with heat transfer by radiation and from the measurements to show the domination of the convective heat transfer coefficient  $H_c$  at low surface temperatures and the domination of the radiation heat transfer coefficient  $H_r$  at high surface temperatures.

#### THEORITICAL BACKGROUND

In general, convection is a heat transfer mechanism in which the heat is transported due to the fluid motion. When the fluid motion is not generated by any external source (like a pump, fan, suction device, etc.), it is called natural convection. In this case, fluid surrounding a heat source receives heat, becomes less dense and rises. The surrounding, cooler fluid then moves to replace it. This cooler fluid is then heated and the process continues forming convection current. Compared to heat transfer by convection, that by thermal radiation requires no material. Radiation maybe viewed as a propagation of electromagnetic waves. All matter with a temperature greater than absolute zero emits thermal radiation.

If a surface, at a temperature above ambient temperature, is located in stationary air then heat will be transferred from the surface to the air. This transfer of heat will be a combination of natural convection and radiation.

Total heat loss due to combined heat transfer by convection and radiation can be expressed as follows:

$$Q_{\text{tot}} = Q_c + Q_r \quad \dots(1)$$

Where heat loss contributed by natural convection is formulated as follows

$$Q_c = H_c A_s (T_s - T_a) \quad \dots(2)$$

while that contributed by radiation is formulated as follows

$$Q_r = H_r A_s (T_s - T_a) \quad \dots(3)$$

Surface area is equal to

$$A_s = GDL \quad \dots(4)$$

The average heat transfer coefficient for natural convection is expressed as follows

$$H_c = \frac{kNu}{D} \quad \dots(5)$$



Nusselt number for the above free convection:

$$N_u = cR_a^n \quad \dots(6)$$

Where c and n can be found from the table provided in the appendix.

$$R_a = \frac{gQ(T_s - T_a)D^3}{\nu\alpha} \quad \dots(7)$$

With

$Q =$  Volumetric thermal expansion coefficient,  $\alpha =$  Thermal Diffusivity, and  $\nu =$  Kinematic Viscosity ... (8)

Physical properties should be evaluated at **average temperature**.

Alternatively, convective heat transfer coefficient can also be calculated using the following relation

$$H_c = 1.32 \left( \frac{T_s - T_a}{D} \right) \quad \dots(9)$$

The value of  $H_c$  should be calculated using both the original and simplified equations and the values compared. Radiative heat transfer coefficient is calculated as follows

$$H_r = \epsilon F \frac{T_s^4 - T_a^4}{T_s - T_a} \quad \dots(10)$$

## DESCRIPTION OF THE EQUIPMENT

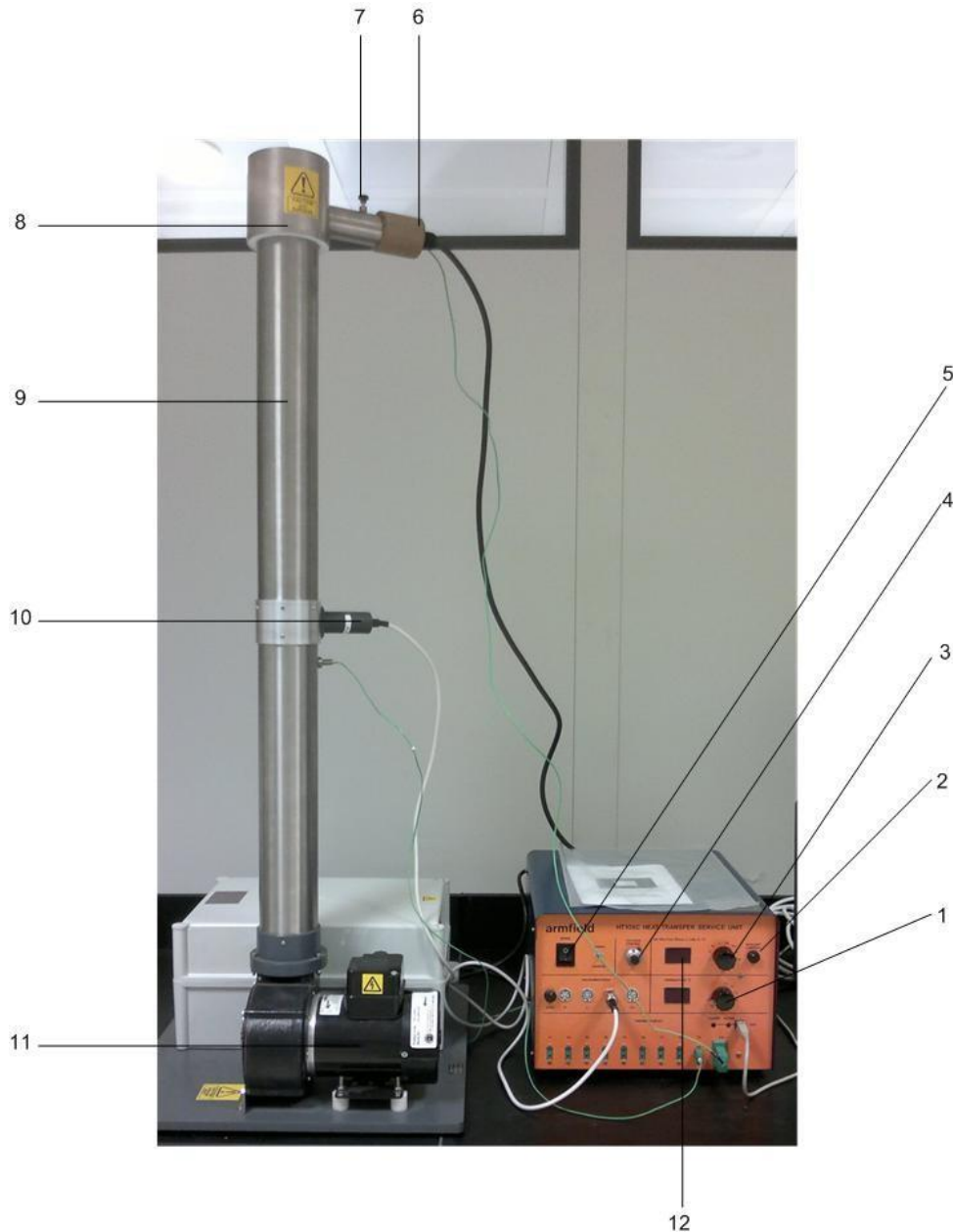

Figure 1. Combined Convection and Radiation Unit

The combined convection and radiation heat transfer unit consists of two main units HT14C (13) and HT10XC (14) which is basically a service unit with main switch (5) to turn on the whole system. The cylindrical heater (8) is placed on top of the duct (9). The temperature at different angular position can be measure by releasing the screw (7) and rotate the thermocouple (6). The air flow can be introduced into the duct using the fan (11) whose flow rate can be controlled using auxiliary control knob (2). The temperature of heater can be adjusted using potentiometer (4). The measurement of different

parameter such as temperature, voltage, current, air flow rate, etc can be read from two digital panels (12) by changing selector switch (1 and 3) accordingly.

### EXPERIMENTAL PROCEDURE

15. Switch on the front mains switch.
16. Set the heater voltage to 3 volts. If using the software, adjust the voltage using control box on the software screen.
17. Allow the HT14C to stabilize and monitor the temperature of the cylinder as indicated by thermocouple T10 using the software display or using the lower selector switch.
18. After T10 stabilizes, take all measurement for T9, T10, V and I.
19. Set the heater at 6 volts
20. If T10 stabilizes, take all measurement for T9, T10, V, and I
21. Do the same procedure for 9 V, 12 V, 16 V and 20 V.

### REFERENCES

Computer Compatible Combined Convection and Radiation, 2010, Experiment Instructions, ARMFIELD

### NOTATION

$A_d$	:	Cross Sectional Area of The Air Duct, $m^2$
$A_h$	:	Surface Area of the heater, $m^2$
$C_p$	:	Specific Heat Capacity, $J/kg.K$
$\Delta T$	:	Temperature Gradient, K
$h$	:	Heat Transfer Coefficient of The Heater, $W/m^2.K$
$m$	:	Mass flow rate of air, $kg/s$
$Q$	:	Heat load, W
$T_1$	:	Air Inlet Temperature, $^{\circ}C$
$T_2$	:	Air Outlet Temperature, $^{\circ}C$
$T_4$	:	Average Surface Temperature, $^{\circ}C$
$Nu$	:	Nusselt Number
$v$	:	Air velocity, $m/s$
$\rho$	:	Air Density, $kg/m^3$
$\sigma$	:	Stefan Boltzmann constant, $W/m^2K$
$\xi$	:	Emmissivity of cylinder

**Appendix  
Technical Data**

Diameter of cylinder : 0.01 m

Length of cylinder : 0.07 m

$\xi$  : 0.95

$\sigma$  :  $56.7 \times 10^{-9} \text{ W/m}^2\text{K}^4$

Table 1. Physical Properties of Air at P= 1 Bar

T in °C	$\rho$ in $\frac{\text{kg}}{\text{m}^3}$	$c_p$ in $\frac{\text{kJ}}{\text{Kg}\cdot\text{K}}$	$\lambda$ in $\frac{\text{W}}{\text{K}\cdot\text{m}}$	$\eta$ in $\frac{\text{kg}}{\text{m}\cdot\text{s}}$	$\nu$ in $\frac{\text{m}^2}{\text{s}}$	$a$ in $\frac{\text{m}^2}{\text{s}}$	Pr
-20	1,3765	1,004	0,02301	16,15	11,73	16,6	0,71
0	1,2754	1,004	0,02454	17,10	13,41	19,1	0,70
20	1,1881	1,007	0,02603	17,98	15,13	21,8	0,70
40	1,1120	1,008	0,02749	18,81	16,92	24,5	0,69
60	1,0452	1,009	0,02894	19,73	18,88	27,4	0,69
80	0,9859	1,010	0,03038	20,73	21,02	30,5	0,69
100	0,9329	1,012	0,03181	21,60	23,15	33,7	0,69
120	0,8854	1,014	0,03323	22,43	25,33	37,0	0,68
140	0,8425	1,017	0,03466	23,19	27,53	40,5	0,68
160	0,8036	1,020	0,03607	24,01	29,88	44,0	0,68
180	0,7681	1,023	0,03749	24,91	32,43	47,7	0,68
200	0,7356	1,026	0,03891	25,70	34,94	51,6	0,68
250	0,6653	1,035	0,04243	27,40	41,18	61,6	0,67
300	0,6072	1,046	0,04591	29,20	48,09	72,3	0,67
400	0,5170	1,069	0,05257	32,55	62,95	95,1	0,66
500	0,4502	1,093	0,05848	35,50	78,86	119	0,66
600	0,3986	1,116	0,0635	38,30	96,08	143	0,67
700	0,3577	1,137	0,0678	40,87	114,3	166	0,69
800	0,3243	1,155	0,0713	43,32	133,6	190	0,70
900	0,2967	1,171	0,0743	45,65	153,9	214	0,72
1000	0,2743	1,185	0,0768	47,88	175,1	237	0,74

Table 2. Coefficients for Rayleigh Number

Ra	c	n
$10^{-9}$ to $10^{-2}$	0.675	0.058
$10^{-2}$ to $10^2$	1.02	0.148
$10^2$ to $10^4$	0.85	0.188
$10^4$ to $10^7$	0.48	0.25
$10^7$ TO $10^{12}$	0.125	0.333

## WORK SHEETS

V (volt)	I (A)	$T_9 = T_a, (^{\circ}\text{C})$	$T_{10} = T_s, (^{\circ}\text{C})$
2			
4			
6			
8			
10			
12			
14			
16			
18			
20			

### Answer the following questions?

- What is the difference between convection and radiation?
- What is the cause of air movement during natural convection?

## EXPERIMENT #06 (HT-06)

### COMBINED FORCED CONVECTION AND RADIATION HEAT TRANSFER

#### OBJECTIVE

1. To determine the effect of forced convection on heat transfer from the surface of cylinder at varying air velocities and surface temperatures.
2. To demonstrate the relationship between air velocity and surface temperature for a cylinder subjected to forced convection.
3. To demonstrate that the local heat transfer coefficient varies around the circumference of a horizontal cylinder when subjected

#### THEORITICAL BACKGROUND

As mentioned in previous experiment that convection is a heat transfer mechanism in which the heat is transported due to the fluid motion. When the fluid motion is generated by any external source (like a pump, fan, suction device, etc.), it is called forced convection.

If a surface, at a temperature above ambient temperature, is located in flowing air then heat will be transferred from the surface to the air. This transfer of heat will be a combination of forced convection and radiation. Total heat loss due to combined heat transfer by convection and radiation can be expressed as follows:

$$Q_{\text{tot}} = Q_{\text{f}} + Q_{\text{r}} \quad \dots(1)$$

Where heat loss contributed by forced convection is formulated as follows

$$Q_{\text{f}} = H_{\text{f}}A_{\text{s}}(T_{\text{s}} - T_{\text{a}}) \quad \dots(2)$$

While that contributed by radiation is formulated as follows

$$Q_{\text{r}} = H_{\text{r}}A_{\text{s}}(T_{\text{s}} - T_{\text{a}}) \quad \dots(3)$$

Surface area is equal to

$$A_{\text{s}} = \pi D L \quad \dots(4)$$

The average heat transfer coefficient for forced convection is expressed as follows

$$H_{\text{f}} = \frac{k N_{\text{u}}}{D} \quad \dots(5)$$

Nusselt number for the above forced convection is expressed as follows

$$N_{\text{u}} = 0.3 + \frac{(0.62 Re^{0.5} Pr^{0.33})}{(1 + \frac{0.4}{Pr})^{0.25}} \left( 1 + \left( \frac{Re}{282000} \right)^{0.5} \right) \quad \dots(6)$$

Where Pr can be found from the table provided in the appendix.

$$Re = \frac{u c D}{\nu}$$

...(7)

With

$$U_c = 1.22U_a \quad \dots(8)$$

Physical properties should be evaluated at average temperature. Radiative heat transfer coefficient is calculated as follows

$$H_r = \epsilon F T_s^4 - T_a^4 \quad \dots(9)$$

### DESCRIPTION OF THE EQUIPMENT

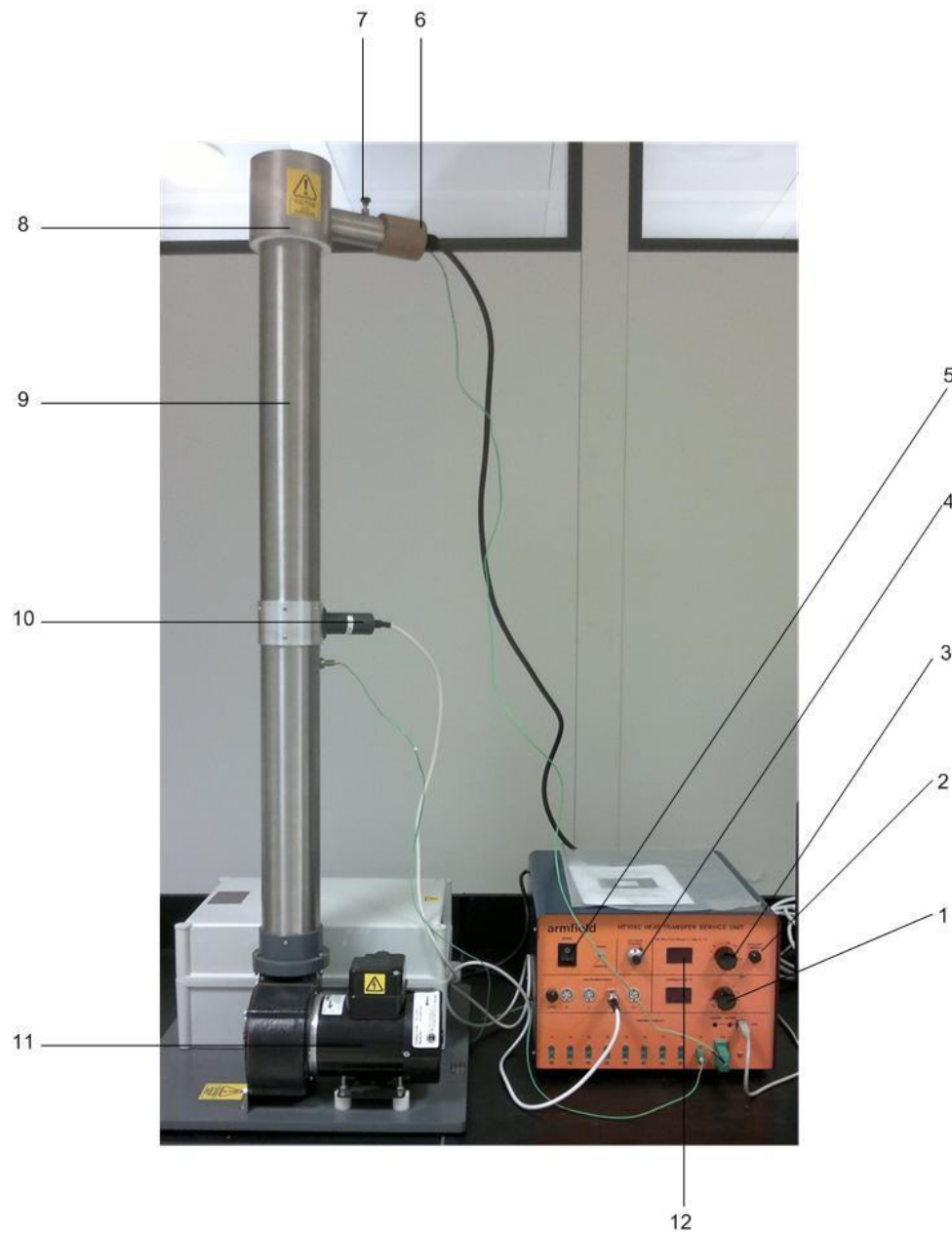

Figure 1. Combined Convection and Radiation Heat Transfer



The combined convection and radiation heat transfer unit consists of two main units HT14C (13) and HT10XC (14) which is basically a service unit with main switch (5) to turn on the whole system. The cylindrical heater (8) is placed on top of the duct (9). The temperature at different angular position can be measure by releasing the screw (7) and rotate the thermocouple (6). The air flow can be introduced into the duct using the fan (11) whose flow rate can be controlled using auxiliary control knob (2). The temperature of heater can be adjusted using potentiometer (4). The measurement of different parameter such as temperature, voltage, current, air flow rate, etc can be read from two digital panels (12) by changing selector switch (1 and 3) accordingly

## EXPERIMENTAL PROCEDURE

1. Switch on the front mains switch.
2. Start the software by clicking the icon HTC 14C combined convection and radiation.
3. Select exercise D and then click diagram icon.
4. Start the centrifugal fan and heater by clicking the power on the diagram screen
5. Set the fan to give flow rate of 1 m/s. Use the software to adjust the fan speed by using the control box on the diagram screen.
6. Set the heater voltage to 20 V. Use the software to adjust the voltage by using the control box on the diagram screen.
7. Select angular position of 0 degree and then click icon GO.
8. Allow the HT14C to stabilize and monitor the temperature of the cylinder as indicated by thermocouple T10 using the software display or using the lower selector switch.
9. If T10 stabilizes, take all measurement for  $U_a$ , T9, T10, V, and I, fill out table 1 in work sheet.
10. Do the same procedure for air flow rate of 1 m/s to 7 m/s with step of 1 m/s.
11. For the air flow rate that is adjusted at 1 m/s and 7 m/s, do the following:
  - a. After T10 stabilizes, take all measurements (as mentioned in step #9).
  - b. Click icon STOP (to stop sampling) and then open the new sheet.
  - c. Rotate the cylinder by 30 degrees and click angular position 30 degree.
  - d. Click icon GO.
  - e. Allow HT14C to stabilize then repeat the above readings which is now for angular position of 30 degrees.
  - f. Continue to rotate the cylinder in steps of 30 degrees and do the same procedure of a – e.

## REFERENCES

Computer Compatible Combined Convection and Radiation, 2010, Experiment Instructions, ARMFIELD

## NOTATION

V	:	Voltage to heated cylinder, V
I	:	Current to heated cylinder, A
$Q_{in}$	:	Power supplied to heated cylinder, W
D	:	Diameter of heated cylinder, m
L	:	Heated length of cylinder, m
$A_s$	:	Heat transfer area, $m^2$
Q	:	Heat load, W
$U_a$	:	Air velocity in duct, m/s

$U_c$	:	Corrected air velocity, m/s
$Q_c$	:	Heat loss due to natural convection, W
$Q_f$	:	Heat loss due to forced convection, W
$Q_r$	:	Heat loss due to radiation, W
$Q_{tot}$	:	Total heat loss from cylinder, W
$H_c$	:	Heat transfer coefficient for natural convection, W/m <sup>2</sup> K
$H_f$	:	Heat transfer coefficient for forced convection, W/m <sup>2</sup> K
$H_r$	:	Heat transfer coefficient for radiation, W/m <sup>2</sup> K
$\sigma$	:	Stefan Boltzmann constant, W/m <sup>2</sup> K
$\xi$	:	Emmissivity of cylinder
F	:	Area factor
$\nu$	:	Dynamic viscosity of air, m <sup>2</sup> /s
k	:	Thermal conductivity of air, W/mK
Re	:	Reynolds number
Nu	:	Nusselt number
Pr	:	Prandtl number
Q	:	Angular position of thermocouple
$T_{10}$	:	Surface temperature of heated cylinder, °C
$T_9$	:	Temperature of ambient air, °C

## Appendix

### Technical Data

Diameter of cylinder : 0.01 m

Length of cylinder : 0.07 m

$\xi$  : 0.95

$\sigma$  :  $56.7 \times 10^{-9} \text{ W/m}^2\text{K}^4$

Table 1. Physical Properties of Air at P= 1 Bar

T in °C	$\rho$ in $\frac{\text{kg}}{\text{m}^3}$	$c_p$ in $\frac{\text{kJ}}{\text{kg}\cdot\text{K}}$	$\lambda$ in $\frac{\text{W}}{\text{K}\cdot\text{m}}$	$\eta$ in $\frac{\text{kg}}{\text{m}\cdot\text{s}}$	$\nu$ in $\frac{\text{m}^2}{\text{s}}$	$a$ in $\frac{\text{m}^2}{\text{s}}$	Pr
-20	1,3765	1,004	0,02301	16,15	11,73	16,6	0,71
0	1,2754	1,004	0,02454	17,10	13,41	19,1	0,70
20	1,1881	1,007	0,02603	17,98	15,13	21,8	0,70
40	1,1120	1,008	0,02749	18,81	16,92	24,5	0,69
60	1,0452	1,009	0,02894	19,73	18,88	27,4	0,69
80	0,9859	1,010	0,03038	20,73	21,02	30,5	0,69
100	0,9329	1,012	0,03181	21,60	23,15	33,7	0,69
120	0,8854	1,014	0,03323	22,43	25,33	37,0	0,68
140	0,8425	1,017	0,03466	23,19	27,53	40,5	0,68
160	0,8036	1,020	0,03607	24,01	29,88	44,0	0,68
180	0,7681	1,023	0,03749	24,91	32,43	47,7	0,68
200	0,7356	1,026	0,03891	25,70	34,94	51,6	0,68
250	0,6653	1,035	0,04243	27,40	41,18	61,6	0,67
300	0,6072	1,046	0,04591	29,20	48,09	72,3	0,67
400	0,5170	1,069	0,05257	32,55	62,95	95,1	0,66
500	0,4502	1,093	0,05848	35,50	78,86	119	0,66
600	0,3986	1,116	0,0635	38,30	96,08	143	0,67
700	0,3577	1,137	0,0678	40,87	114,3	166	0,69
800	0,3243	1,155	0,0713	43,32	133,6	190	0,70
900	0,2967	1,171	0,0743	45,65	153,9	214	0,72
1000	0,2743	1,185	0,0768	47,88	175,1	237	0,74

### WORK SHEETS

V (volt)	$U_a$ (m/s)	I (A)	$T_9 = T_a$ , (°C)	$T_{10} = T_s$ , (°C)
20	1			
	2			
	3			
	4			
	5			
	6			
	7			

V (volt)	Position	$U_a = 1$ m/s			$U_a = 7$ m/s		
		$T_9 = T_a$ , (°C)	$T_{10} = T_s$ , (°C)	I (A)	$T_9 = T_a$ , (°C)	$T_{10} = T_s$ , (°C)	I(A)
20	0						
	30						
	60						
	90						
	120						
	180						

Answer the following questions

- a. What is the cause of air movement during forced convection?
- b. What are parameters that can affect heat transfer by radiation?

## EXPERIMENT # 07 (HT-07)

### STEADY STATE HEAT TRANSFER IN HEAT EXCHANGER (1)

#### OBJECTIVE:

To compare the performance of heat exchanger at parallel flow and counter flow operation.

Determination of heat transfer coefficient in tubular heat exchanger and representation of temperature curves.

#### THEORITICAL BACKGROUND:

The heat exchanger service unit is used for indirect heat transfer. In indirect heat transfer the heat is transferred from one fluid to another through a partition in a heat exchanger. The fluid flows on the two sides of the partition do not mix. In terms of the flow directions of the fluids on both sides of the partition, we differentiate between parallel flow, counter flow and cross flow. In other words the fluid either flow in the same direction, in opposing directions or perpendicular to one another.

The tubular heat exchanger consists of two double tubes. In the double tubes, the transparent outer tube allows the stainless steel inner tube to be seen. Two separate areas are created, the tube area (inside the inner tube) and the shell area (between the inner tube and outer tube).

The heat flow ( Q ) is determined from the mass flow rate m, the specific heat capacity and the absolute temperature (T).

$$Q = m C_p T \quad \dots(1)$$

For hot fluid

$$Q = m_h C_{ph} (T_{h,in} - T_{h,out}) \quad \dots(2)$$

For cold fluid

$$Q = m_c C_{pc} (T_{c,out} - T_{c,in}) \quad \dots(3)$$

With no exchange of heat with the surroundings

$$Q = Q_h = Q_c$$

If the heat flow figures differ, the main value  $Q_m$  is calculated as,

$$Q_m = Q_h + Q_c / 2 \quad \dots(4)$$

This enables the mean coefficient of heat transfer  $K_m$  for the heat exchanger to be calculated

$$K_m = Q_m / A_m \Delta T_{lm} \quad \dots(5)$$

Where,

$$\Delta T_{lm} = \Delta T_{max} - \Delta T_{min} / \ln [\Delta T_{max} / \Delta T_{min} ] \quad \dots(6)$$

For parallel flow

$$\Delta T_{max} = T_{h,in} - T_{c,in} \quad \dots(7)$$

$$\Delta T_{min} = T_{h,out} - T_{c,out} \quad \dots(8)$$

For counter flow

$$\Delta T_{max} = T_{h,in} - T_{c,out} \quad \dots(9)$$

$$\Delta T_{min} = T_{h,out} - T_{c,in} \quad \dots(10)$$

### DESCRIPTION OF THE EQUIPMENT

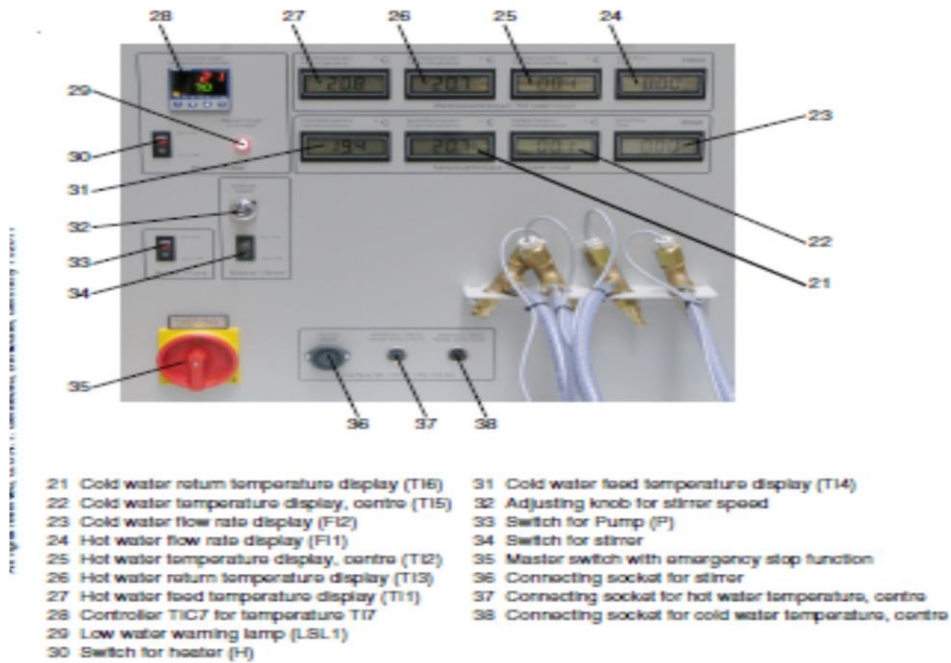

Figure 1. Detail of Control and display panel

The equipment consists of WL-110 series heat exchanger with service unit along with a water chiller. The master switch for the equipment is used for main on off (35) of the

equipment. The liquid flow is controlled by pump controller (32). The temperature of the heater is controlled by temperature controller (28). The temperature of the inlet and outlet for cold as well for hot fluid fluids are displayed on the console.

The whole schematic as well as the process schematic of the equipment is shown in the figure 2 and 3.



Figure 2. Service unit with tubular Heat Exchanger.

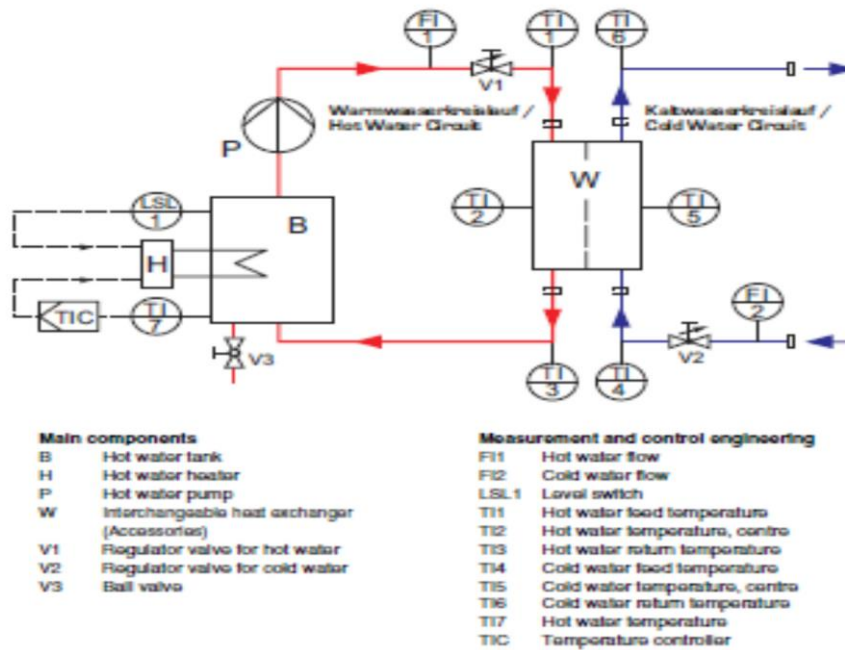

Figure 3. Process Schematic

### EXPERIMENTAL PROCEDURE:

The experimental procedure is as follows

1. Set the main switch to "1".
2. Check the water level in the hot water tank. If the hot water is empty add water until the low level is reached.
3. Start the PC. Start the data acquisition program.
4. Open the cold water feed at the cold water mains.
5. Open the regulator valve for cold water V2.
6. Open the regulator valve for hot water V1.
7. Start the pump (P).
8. Turn on the heater and set the desired hot water set point SP (T7).
9. Set the desired hot and cold water flow rates.
10. Observed the measured values. Wait until a steady state is reached.

### REFERENCES

Heat exchanger with service Unit, 2011, Experiment Instructions, GUNT.



## NOTATION

A	:	Heat Transfer Area, m <sup>2</sup>
A <sub>m</sub>	:	Mean heat transfer area, m <sup>2</sup>
C <sub>p</sub>	:	Specific Heat Capacity, J/kg.K
ΔT <sub>lm</sub>	:	Logarithmic mean temperature difference, K
h	:	Heat Transfer Coefficient, W/m <sup>2</sup> .K
m	:	Mass flow rate, kg/s
Q	:	Amount of heat, KJ
K <sub>m</sub>	:	Mean coefficient of heat transfer, KW/m <sup>2</sup> .K
ρ	:	Density, kg/m <sup>3</sup>

## Appendix

### Technical Data

Mean logarithmic heat transfer area: 0.05m<sup>2</sup>

## WORK SHEET

Experiment	H.E	Flow direction	$V_c, V_h,$ lit/min	T7, C	T1, C	T3, C	T4, C	T6, C	$K_m, KW/m^2K$	$Q_m, KW$

Answer the following questions

Q.1 what are heat exchangers? Enlist some uses of the heat exchangers?

Q.2 Differentiate direct and indirect heat transfer?

## EXPERIMENTHT#08 (HT-08)

### STEADY STATE HEAT TRANSFER IN HEAT EXCHANGER (2)

#### OBJECTIVE:

Investigate the effect of water flow rate on the rate of heat transfer.

#### THEROTICAL BACKGROUND:

The shell and tube heat exchanger consist of tubes and transparent shell allows the tube bundle to be seen. The bundle is an assembly consisting of parallel tubes ( seven tubes in this case). These seven tubes are soldered to the tube plates on both sides. This creates two separate areas, the tubular area and the shell area.

The shell area is divided by four baffle plates. They deflect the fluid in the shell area, thus improving the heat exchange. The flow in the shell area is essentially perpendicular to the tubes, i-e the direction of flow is cross. But the flow can run in the same direction or in opposite directions i-e cross parallel flow and cross counter flow.

The hot water enters in the tube side while the cold water enters in the shell side, the flow rates of hot water and cold water varies i-e 0.7, 1.4, 2.1 (l/ min) and notice the effect on the mean coefficient of heat transfer  $K_m$  , and mean heat transfer  $Q_m$ .

#### DESCRIPTION OF THE EQUIPMENT

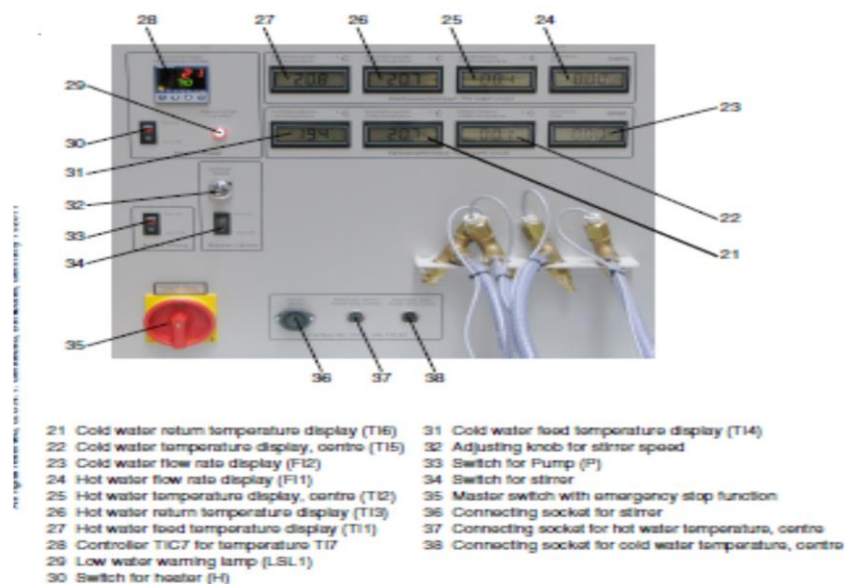

Figure 1. Detail of Control and display Panel

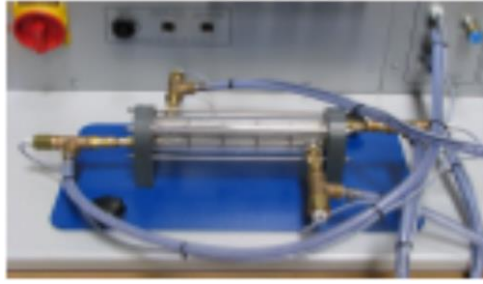

Figure 2. Connection for Shell & Tube heat Exchanger.

### EXPERIMENTAL PROCEDURE:

The experimental procedure is as follows

1. Set the main switch to "1".
2. Check the water level in the hot water tank. If the hot water is empty add water until the low level is reached.
3. Start the PC. Start the data acquisition program.
4. Open the cold water feed at the cold water mains.
5. Open the regulator valve for cold water V2.
6. Open the regulator valve for hot water V1.
7. Start the pump (P).
8. Turn on the heater and set the desired hot water set point SP (T7).
9. Set the desired hot and cold water flow rates. i-e 0.7 l/min
10. Then varies the flow rates i-e, 1.4, 2.1 and observed the measured values. Wait until a steady state is reached.

### REFERENCES:

Heat exchanger with service Unit, 2011, Experiment Instructions, GUNT.

### NOTATION

A	:	Heat Transfer Area, m <sup>2</sup>
A <sub>m</sub>	:	Mean heat transfer area, m <sup>2</sup>
C <sub>p</sub>	:	Specific Heat Capacity, J/kg.K
ΔT <sub>lm</sub>	:	Logarithmic mean temperature difference, K
h	:	Heat Transfer Coefficient, W/m <sup>2</sup> .K
m	:	Mass flow rate, kg/s
Q	:	Amount of heat, KJ
K <sub>m</sub>	:	Mean coefficient of heat transfer, KW/m <sup>2</sup> .K
ρ	:	Density, kg/m <sup>3</sup>

## WORK SHEET

Experiment	H.E	Flow direction	$V_c, V_h,$ lit/min	T7, C	T1, C	T3, C	T4, C	T6, C	$K_m, KW/m^2K$	$Q_m, KW$

Answer the following questions

Q.1 what is the effect of flow rates of the shell side and tube side fluids on heat transfer?

Q.2 what is the effect of number of tubes on the heat transfer rate?

## EXPERIMENT # 09 (HT-09)

### STEADY STATE HEAT TRANSFER IN HEAT EXCHANGER (3)

#### OBJECTIVE:

Investigate the effect of hot water temperature on the rate of heat transfer.

Comparison of temperature curves for different types of heat exchangers.

#### THEORETICAL BACKGROUND:

In this case the plate heat exchanger is used to investigate the effect of hot water flow rate on  $km$  and  $Q_m$ . Plate heat exchanger is made of six plates soldered together, which form two separate flow channels. The solder points seal the plates against one another.

Openings in the plate allow the media to flow. The surface of the plate is not smooth but has a characteristic profile. This causes narrow flow cross sections to be established in the spaces, in which significant turbulences occur. The turbulent flow facilitates efficient heat transfer and also has a self cleaning effect. The wall thicknesses of the heat transfer areas are generally smaller than in tubular heat exchangers.

Plate heat exchanger has several applications in various chemical industries, like petrochemicals, food industry, Chemical plants etc.

#### DESCRIPTION OF THE EQUIPMENT

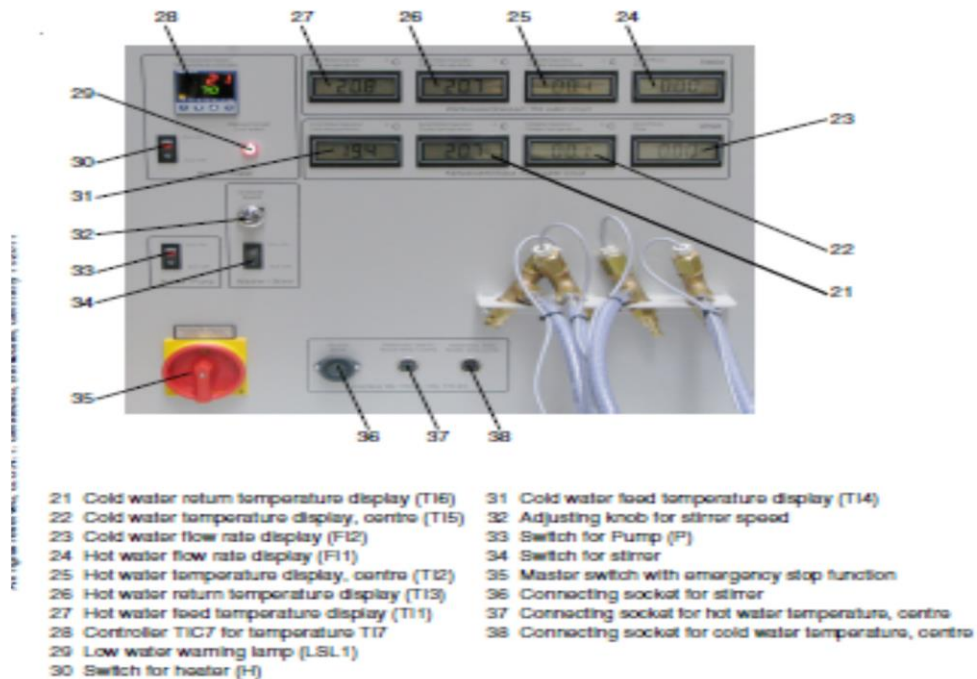

Figure 1. Detail of Control and display Panel

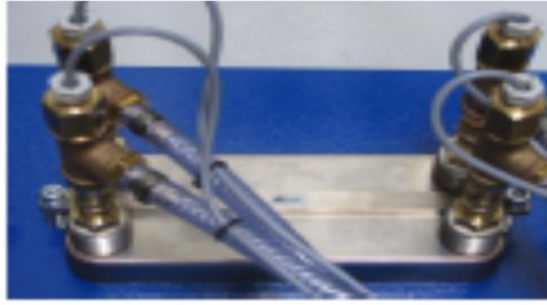

Figure 2. Connection for plate Heat Exchanger

### EXPERIMENTAL PROCEDURE:

The experimental procedure is as follows

1. The experimental procedure is as follows
2. Set the main switch to "1".
3. Check the water level in the hot water tank. If the hot water tank is empty add water until the low level is reached.
4. Start the PC. Start the data acquisition program.
5. Open the cold water feed at the cold water mains.
6. Open the regulator valve for cold water V2.
7. Open the regulator valve for hot water V1.
8. Start the pump (P).
9. Turn on the heater and set the desired hot water set point SP (T7).
10. Set the desired hot and cold water flow rates.
11. Then start changing the hot water temperature, i-e, 25, 45, 70 Co
12. Observed the measured values. Wait until a steady state is reached.

### REFERENCES:

Heat exchanger with service Unit, 2011, Experiment Instructions, GUNT.

### NOTATION

A	:	Heat Transfer Area, m <sup>2</sup>
A <sub>m</sub>	:	Mean heat transfer area, m <sup>2</sup>
C <sub>p</sub>	:	Specific Heat Capacity, J/kg.K
ΔT <sub>lm</sub>	:	Logarithmic mean temperature difference, K
h	:	Heat Transfer Coefficient, W/m <sup>2</sup> .K
m	:	Mass flow rate, kg/s
Q	:	Amount of heat, KJ
K <sub>m</sub>	:	Mean coefficient of heat transfer, KW/m <sup>2</sup> .K
ρ	:	Density, kg/m <sup>3</sup>

## WORK SHEET

Experiment	H.E	Flow direction	$V_c, V_h,$ lit/min	T7, C	T1, C	T3, C	T4, C	T6, C	$K_m, KW/m^2K$	$Q_m, KW$

Answer the following questions

Q.1 what is meant by effectiveness of heat exchanger?

Q.2 How the temperature of the entering hot fluid effect the heat transfer coefficient?



## EXPERIMENT # 10 (HT-10)

### FILM AND DROP WISE CONDENSATION

#### OBJECTIVE:

1. To observe physically film and drop wise condensation process.
2. Determination of heat transfer coefficients for copper and gold condensers.

#### THEORITICAL BACKGROUND:

The process of condensation is an important prerequisite for the design and construction of condensers in power plants and processing plants. Condensation occurs when steam comes into contact with a wall that has a temperature lower than the saturation temperature of the steam, the steam precipitates as liquid. The condensate can take the form of a continues film or individual drops of liquid on the wall. Hence the terms film and drop condensation are used.

In practice film condensation usually occurs. Drop condensation only occurs on very smooth surfaces that cannot be wet. The transfer of heat is much higher in the case of drop condensation than for film condensation since there is no continuous liquid film to isolate the steam from the wall.

Since smooth surfaces that cannot be wet are not realizable in practice over long term, the poorer, but more certain values of film condensation are usually assumed. One of the condensers on the test stand is polished and gold plated to provide a durable surface that cannot be wet. In addition the surface must be perfectly clean. It is for this reason that only pure distilled water may be used.

Different forms of condensation process, that is film and drop wise condensation, can be demonstrated. The condensation process takes place in a glass cylinder so that the action of condensation is clearly visible. The test stand is operated with distilled water in a vacuum. This enables the temperature to be kept under 100C.

The energy transferred is determined from the cooling water flow rate.

$$Q = \dot{m} C_p ( T_{out} - T_{in} ) = \rho V C_p ( T_{out} - T_{in} ) \quad \dots(1)$$

In this equation V is the cooling water flow rate,  $T_{out}$  is return temperature and  $T_{in}$  is feed temperature of the cooling water. The heat capacity  $C_p$  and the density at the mean coolant temperature are used.

$$T_{cm} = ( T_{out} - T_{in} ) / 2 \quad \dots (2)$$

The coefficient of heat transmission ( $\alpha$ ) is determined by the following relation.

$$\alpha = Q / A ( T_s - T_w ) \quad \dots(3)$$

## DESCRIPTION OF THE EQUIPMENT



Abb. 2.1 View of the Test Stand

- |   |                                     |
|---|-------------------------------------|
| 1 Table Top Stand                                     | 11 Pressure Switch                  |
| 2 Main Switch   | 12 Condensate Separator             |
| 3 Heater Switch                                       | 13 Vessel                           |
| 4 Heater Power Adjuster                               | 14 Condenser Pipes                  |
| 5 Vessel Pressure Display                             | 15 Vacuum Pump (inside the cabinet) |
| 6 Vessel Temperature Display T7                       | 16 Vacuum Pump Adjustment Valve     |
| 7 Cooling Water Flow Rate Displays<br>F1, F2          | 17 Cooling Water Control Valve      |
| 8 Temperature Displays<br>Condenser Surface T3, T6    | 18 Vessel Fill and Drain Valve      |
| 9 Temperature Displays<br>Cooling Water Outlet T2, T5 | 19 Heater                           |
| 10 Temperature Displays<br>Cooling Water Inlet T1, T4 | 20 Cooling Water Feed               |
|   | 21 Cooling Water Return             |
|   | 22 Drop Collector                   |
|   | 23 Socket for PC Interface          |
|   | 24 Mains Connection                 |

Figure 1. Condensation Unit

### Experimental Procedure:

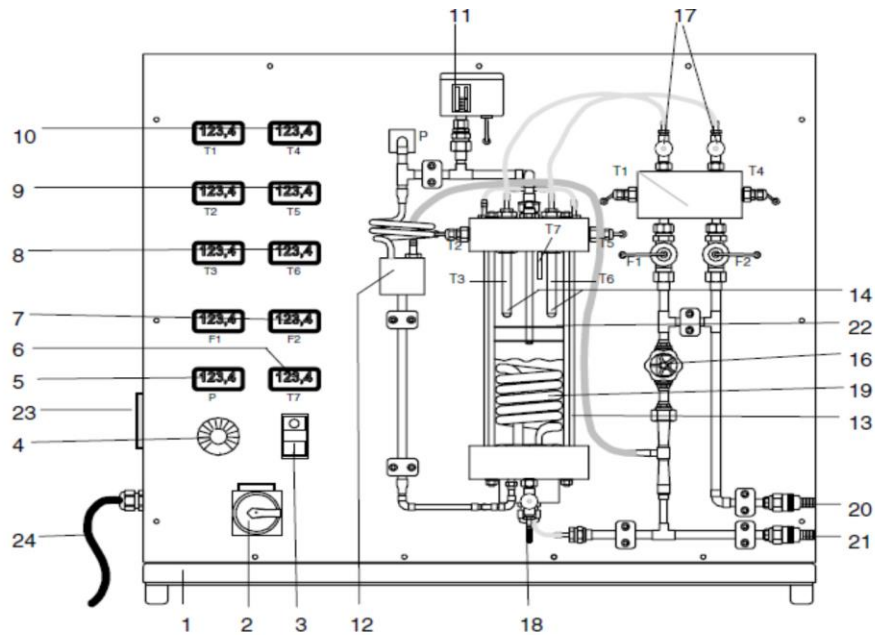
1. First create vacuum in a glass cylinder by using water jet pump up to 0.3 bars.
2. Close the water jet pump and switch the heater and heat up to around 80C at half power.
3. Start the water jet pump again, this will drop the pressure inside the vessel and the water start boiling vigorously.
4. Heat the vessel up to 90C (T<sub>7</sub>).
5. Adjust the cooling water flow rates ( V1 and V2) in order to achieve the desired difference between surface temperature and steam temperature for gold and copper both.
6. Adjust the heater power so that the steam temperature remains constant.

7. If necessary readjust the flow rate of the cooling water to keep the difference between the surface temperature and the steam temperature constant i-e 10C.
8. Once we observed the condensation on both the condensers, read out all the temperatures, flow rates and record.

#### **REFERENCES:**

WL 230 condensation Unit, 2011, Experiment Instructions, GUNT.

#### **NOTATION**

A	:	Condenser surface Area, m <sup>2</sup>
h	:	Height of condenser, m
C <sub>p</sub>	:	Specific Heat Capacity, J/kg.K
ΔT <sub>lm</sub>	:	Logarithmic mean temperature difference, K
α	:	Heat Transfer Coefficient , W/m <sup>2</sup> .K
m	:	Mass flow rate, Kg/s
P	:	Pressure , N/m <sup>2</sup>
V	:	Volumetric flow rate, m <sup>3</sup> /s
ρ	:	Density, kg/m <sup>3</sup>

#### **Appendix Technical Data**

Surface area of the condenser: 0.05m<sup>2</sup>

## WORK SHEETS

**For film condensation:**

Film condensation		
Cooling water Inlet temperature, C (T1 )		$\alpha$ , KW/m <sup>2</sup> K
Cooling water outlet temperature, C (T2 )		
Cooling water flow rate, l/h ( F2)		
Surface Temperature, C ( T3)		
Steam Temperature, ( T 7)		

**For Drop-wise Condensation:**

Drop condensation		
Cooling water Inlet temperature, C (T4 )		$\alpha$ , KW/m <sup>2</sup> K
Cooling water outlet temperature, C (T5 )		
Cooling water flow rate, l/h ( F1)		
Surface Temperature, C ( T6)		
Steam Temperature, ( T 7)		

Answer the following questions

Q1 Differentiate between film and drop wise condensation?

Q2 what type of condensers used for drop wise condensation?

Q3 Enlist some industrial applications of the condensers?

## EXPERIMENT #11 (HT-11)

### NUCLEATE BOILING

#### OBJECTIVE

1. To observe the physical phenomena occurs during boiling process.
2. To relate heat transfer coefficient to the physical phenomena.

#### THEORITICAL BACKGROUND

The nucleate boiling process has a complex nature. Only a limited number of experimental studies provided valuable insights into the boiling phenomena while knowledge of the evaporation process is an essential requirement for the design and construction of stream generators. The evaporation process consists of several different boiling forms which will be investigated in this experiment.

The boiling process starts from room temperature will follow several steps before the liquid reach boiling temperature. At the beginning, liquid that has been heated up to boiling temperature moves upward due to upwelling and evaporates mainly at the heating surface. At the same time heat transfer occurs by natural convection and no bubbles can be seen. Heat transfer coefficient indeed increases with the heating surface load in which in turn increases with the temperature gradient between the heating surface and the liquid.

Nucleate boiling is characterized by the growth of bubbles or pops on a heated surface, which rise from discrete points on a surface, whose temperature is only slightly above the liquid's temperature. In general, the number of nucleation sites are increased by an increasing surface temperature. Thus nucleate boiling region starts with the formation of bubbles until the critical temperature at which the heat flux starts decreasing although the surface temperature keeps increasing. This happens because a film of vapor forms between the heating surface and the liquid and acts as an additional thermal resistor. The heat transfer coefficient after this critical temperature also decreases noticeably. The decrease typically reaches approximately the value it was at during free convection.

Heating surface load or flux that happen on the surface of the heater can be calculated as follows:

$$q' = \frac{Q}{A} \quad \dots(1)$$

While heat transfer coefficient occurs between liquid and surface of heater can be obtained from

$$h_b = \frac{Q'}{A(T_c - T_l)} \quad \dots(2)$$

The heat transfer resistance is calculated as follows

$$R_{u''} = \frac{(T_c - T_l)}{Q'} = \frac{1}{h_b} \quad \dots(3)$$

Q  $h\nu$

The inverse of boiling or evaporation process is condensation which is also observed in this experiment. When wall temperatures below the saturation temperature of a vapor contact with the wall, the vapor begins to condense. Even if the mean vapor temperature is still above the saturation temperature, the condensation can run down the wall as a liquid film or in drops. In the experiment, the condensation process is boost using cooling water. Therefore, the heat removal during condensation process can be simply calculated as follows:

$$\dot{Q}_c = N_w C_{pw} (T_2 - T_1) \quad \dots(4)$$

While the heat transfer coefficient occurs between vapor and cooler surface can be obtained from

$$h_c = \frac{\dot{Q}_c}{A_c \Delta T_N} \quad \dots(5)$$

While  $\Delta T_m$  can be calculated as follows

$$\Delta T_N = \frac{T_2 - T_1}{\ln \frac{T_v - T_1}{T_v - T_2}} \quad \dots(6)$$

## DESCRIPTION OF THE EQUIPMENT

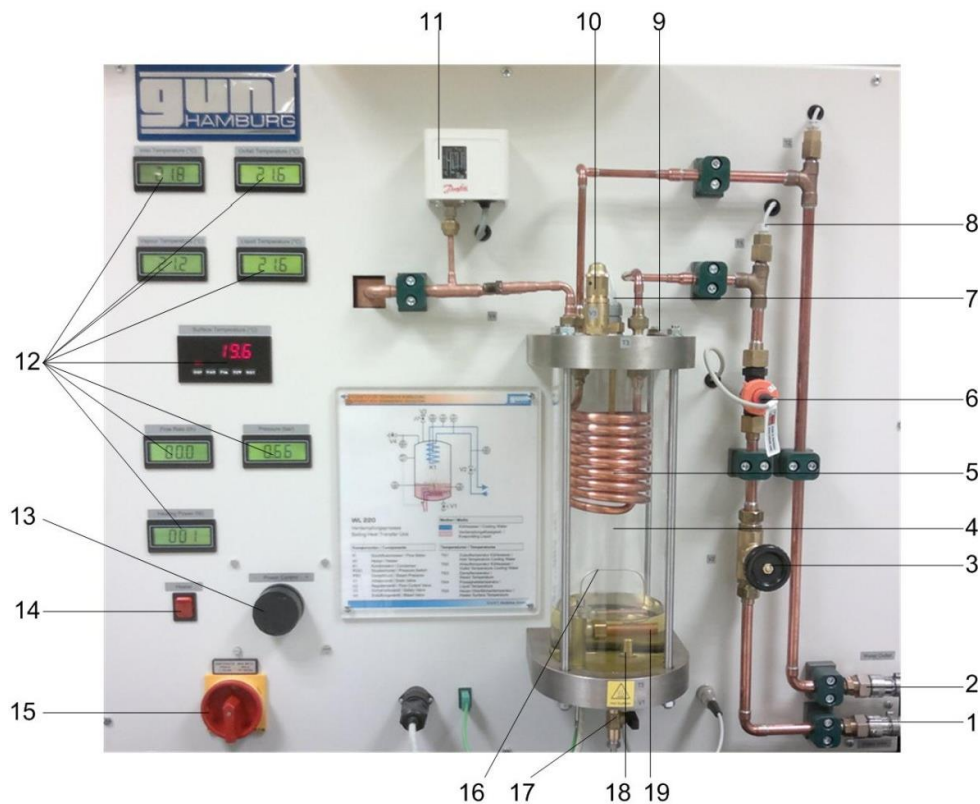

Figure 1. Layout of Boiling Heat Transfer Unit

The unit consists of mainly the glass cylinder (4) contains a water condenser (5) in the upper part and heater (19) in the lower part. Liquid, vapor and surface heater temperatures are measured by temperature sensor (7) and (8) and thermocouple (16) respectively. The vapor pressure inside the cylinder is also measured (11). For safety purpose, the cylinder is equipped with safety valve (10) for pressure. The condenser is connected to cooling water entering through the inlet pipe (1) and leaving through the outlet pipe (2). Its flow rate is measure by flow meter (6) and adjusted by valve (3). The liquid can be put into the cylinder through refilling screw (9) located on the top of cylinder. All parameters including temperature, pressure, and flow rate can be read from the digital displays (12). The unit has one main switch (15) and one switch (14) for heater separately. The heater power can be adjusted using heater power adjuster (13).

## EXPERIMENTAL PROCEDURE

### Creating Vacuum

1. Remove the air inside the glass cylinder by setting the heating capacity to 250 W.
2. Open the air bleed valve with a prick by pushing the inner piston when the pressure of 1.2 bar abs. is reached.
3. Keep pricking the valve until a liquid film runs down on the glass cylinder.
4. Turn off the heater and wait until the pressure of approximately 0.6 bar abs. is obtained.
5. If this is not the case, repeat venting process (step 1 – 4).

### Running the Experiment

1. Turn on the heater and set it at power of 15 W. Read all pressure and temperature when small bubbles can be seen on the surface heater. Record all physical phenomena occurs during the process.
2. Increase the heater power to 25 W. Read all pressure and temperature when small bubbles are released from the surface heater. Record all physical phenomena occurs during the process.
3. Increase the heater power to 100 W. Read all pressure and temperature when bubble formation is more pronounced. Record all physical phenomena occurs during the process.
4. Open the water valve and set it at volumetric flow rate at 80 L/h. read all temperatures when the system reaches steady state.

## REFERENCES

Boiling Heat Transfer Unit, 2011, Experiment Instruction, GUNT

## NOTATION

$A_c$  : Surface Area of the cooler,  $m^2$   $A_h$   
 : Surface Area of the heater,  $m^2$   $C_{pw}$  :  
 Specific Heat Capacity, J/kg.K  
 $\Delta T_m$  : Log Mean Temperature Difference **50**  
 $h_b$  : Heat Transfer Coefficient of The Heater,  
 $W/m^2.K$   
 $h_c$  : Heat Transfer Coefficient of the cooler  
 $m_w$  : Mass flow rate of water, kg/s



q : Heat Flux, W/m<sup>2</sup>  
Q : Heat Power, W  
Q<sub>c</sub> : Heat Load by Cooler, W  
R<sub>u</sub> : Heat Transfer Resistance, K/W  
T<sub>1</sub> : Water Inlet Temperature, °C  
T<sub>2</sub> : Water Outlet Temperature, °C  
T<sub>l</sub> : Liquid Temperature, °C  
T<sub>s</sub> : Surface Temperature, °C  
T<sub>v</sub> : Vapor Temperature, °C

## Appendix

### Technical Data

Heater : 250 W max., surface area : 0.001875 m<sup>2</sup>  
Cooler : Surface area : 0.0578 m<sup>2</sup>

### Liquid

Name : Pentafluorobutane/perfluoropolyether  
Trade name : Solkatherm SES 36  
Molecular Weight : 184.5 g/mol  
Liquid Density (25°C) : 1.363 g/cm<sup>3</sup>.  
Vapor Density (25°C) : 0.0058 g/cm<sup>3</sup>.  
Heat of vaporization : 117.8 J/g  
Specific Heat Capacity: 1.25 J/g.K

Measured values	Run 1	Observation	Run 2	Observation	Run 3	Observation	Run 4	Observation	Run 5	Observation
Electrical Power (P), W	0		15		25		100		100	
Water Flow rate (v), l/h	0		0		0		0		40	
Inlet Temp. (T <sub>1</sub> ), °C										
Outlet Temp. (T <sub>2</sub> ), °C										
Vapor Temp. (T <sub>v</sub> ), °C										
Liquid Temp. (T <sub>l</sub> ), °C										
Surface Temp. (T <sub>s</sub> ), °C										
Absolute Pres. (p), atm										

Based on the above measurement, fill out the following table:

Calculated Values	Run 1	Run 2	Run 3	Run 4	Run 5
Temperature Difference (T <sub>s</sub> -T <sub>l</sub> )					
Heat Flux/load of the heater					
Heat Transfer Coefficient of the heater					
Heat Transfer Resistance of the heater					
Log Mean Temperature around cooler					
Heat Flux Removal					
Heat Transfer Coefficient around Cooler					

Answer the following questions:

- a. When does the nucleate boiling phenomenon start to occur?
- b. What is the type of heat transfer that occurs at the beginning of the boiling process?