

WL 320

Wet cooling tower



Description

- principle and characteristic variables of a wet cooling tower with forced ventilation
- transparent, easily interchangeable cooling column with wet deck surface
- 4 additional cooling columns available as accessory

Wet cooling towers are a proven method of closed-circuit cooling and heat dissipation. Typical areas of application are: air conditioning, heavy industry and power plants.

In wet cooling towers the water to be cooled is sprayed over a wet deck surface. Water and air come into direct contact in the counterflow. The water is cooled by convection. Some of the water evaporates and the evaporation heat removed further cools down the water.

WL 320 examines the main components and principle of a wet cooling tower with forced ventilation. Water is heated in a tank and transported by a pump to an atomiser. The atomiser sprays the water to be cooled over the wet deck surface. The water trickles from the top to the bottom along the wet deck surface whilst air flows from the bottom to the top. The heat is transferred directly from the water to the air by convection and evaporation.

The evaporated water volume is recorded. The air flow is generated by a fan and adjusted using a throttle valve.

The cooling column is transparent allowing clear observation of the wet deck surface and the trickling water. Interchangeable cooling columns (WL 320.01 – WL 320.04) enable comparative studies. GUNT software for data acquisition via USB under Windows 7, 8.1, 10

All important process parameters are recorded (volumetric air flow rate, temperatures of air and water, air humidity, water flow rate). The measured values can be read on digital displays. At the same time, the measured values can also be transmitted directly to a PC via USB. The data acquisition software is included. The changes of state of the air are represented in an h-x diagram.

Learning objectives/experiments

- thermodynamic principles of the wet cooling tower
- changes of state of the air in the h-x diagram
- determination of the cooling capacity
- energy balances
- calculation of process parameters, such as maximum cooling distance, cooling zone width etc.
- in conjunction with the cooling columns WL 320.01-WL 320.04
 - ▶ comparison of different wet deck surfaces

WL 320

Wet cooling tower



1 nozzle as atomiser, 2 wet deck surface, 3 displays and controls, 4 air chamber, 5 fan with throttle valve, 6 pump, 7 tank with heating, 8 tank for additional water, 9 combined temperature/humidity sensor

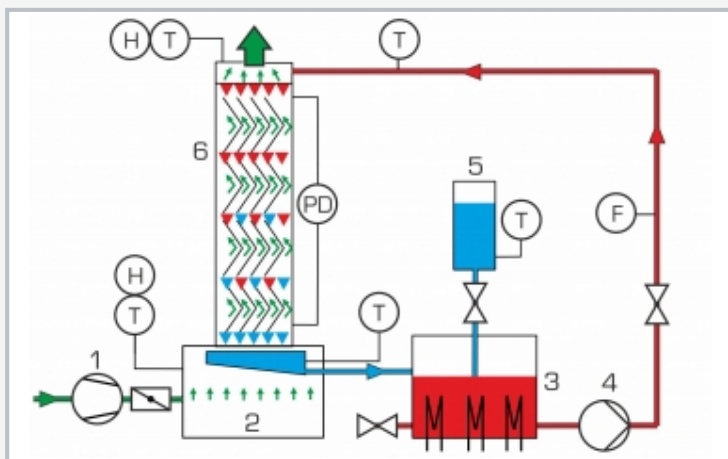

1 fan, 2 air chamber, 3 tank with heater, 4 pump, 5 tank for additional water, 6 cooling column with wet deck surface; T temperature, H humidity, dp differential pressure, F water flow rate

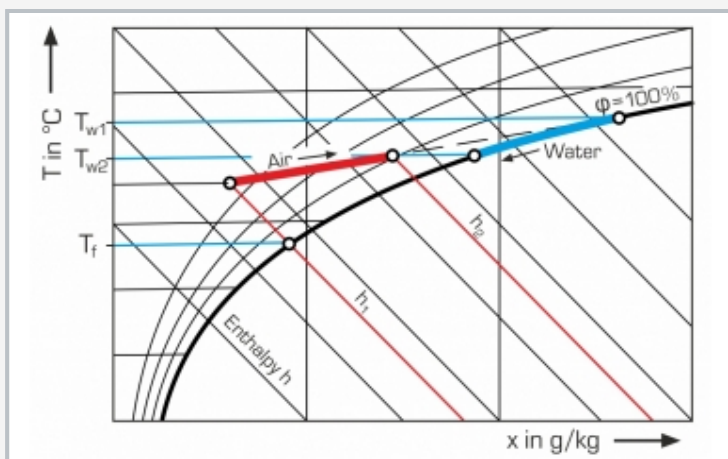

Changes of state of air and water in the h-x diagram as online representation in the software

Specification

- [1] principle of a wet cooling tower with cooling column and forced ventilation
- [2] interchangeable cooling columns with different wet deck surfaces available as accessories
- [3] water circuit with pump, filter, valve and a nozzle as atomiser
- [4] three-stage heater with thermostat for water heating
- [5] radial fan for forced ventilation
- [6] throttle valve to adjust the air flow
- [7] demister unit at the outlet of the cooling columns minimises water loss
- [8] tank for additional water compensates for water loss
- [9] display of temperature, differential pressure, flow rate and humidity
- [10] GUNT software for data acquisition via USB under Windows 7, 8.1, 10

Technical data

Cooling column

- specific surface of the wet deck surface: $110\text{m}^2/\text{m}^3$
- cross-section: $150 \times 150\text{mm}$

Volumetric air flow measurement via orifice: $\varnothing 80\text{mm}$

Heater, adjustable in three stages:

- 500W
- 1000W
- 1500W

Thermostat: switches off at 50°C

Fan

- power consumption: 250W
- max. pressure difference: 4,3mbar
- max. volumetric flow rate: $13\text{m}^3/\text{min}$

Pump

- max. head: 70m
- max. flow rate: 100L/h

Tank for additional water: 4,2L

Measuring ranges

- differential pressure: 0...10mbar [air]
- flow rate: 12...360L/h [water]
- temperature: 2x 0... 50°C , 3x 0... 100°C
- rel. humidity: 10...100%

230V, 50Hz, 1 phase

230V, 60Hz, 1 phase; 230V, 60Hz, 3 phases

UL/CSA optional

LxWxH: 1100x470x1230mm

Weight: approx. 120kg

Required for operation

PC with Windows recommended

Scope of delivery

- 1 trainer
- 1 cooling column type 1
- 1 GUNT software CD + USB cable
- 1 set of instructional material

WL 320

Wet cooling tower

Optional accessories

060.32001	WL 320.01	Cooling column, type 2
060.32002	WL 320.02	Cooling column, type 3
060.32003	WL 320.03	Cooling column, type 4
060.32004	WL 320.04	Cooling column, type 5
020.30009	WP 300.09	Laboratory trolley